



Advanced Card Systems Ltd.
Card & Reader Technologies

ACR1555U



Reference Manual V1.21



Table of Contents

1.0.	Introduction	5
1.1.	ACR1555U-A1 Version.....	5
1.2.	Symbols and Abbreviations	5
2.0.	Features	6
3.0.	ACR1555U Architecture.....	7
3.1.	Reader Block Diagram.....	7
3.2.	Communication between PC/SC driver and PICC and SAM	8
4.0.	Hardware Design	9
4.1.	Battery	9
4.1.1.	Battery Charging and usage guideline	9
4.1.2.	Battery Life	10
4.2.	Bluetooth	10
4.3.	USB	10
4.3.1.	Communication Parameters.....	10
4.3.2.	Endpoints.....	11
4.4.	Contactless Smart Card Interface.....	11
4.4.1.	Carrier Frequency	11
4.4.2.	Card Polling	11
4.5.	User Interface	12
4.5.1.	LED.....	12
4.5.2.	Buzzer	13
4.5.3.	Key	14
5.0.	Software Design	15
5.1.	Reader’s Mode selection	15
5.2.	Bluetooth Communication	16
5.2.1.	Bluetooth Connection Flow	16
5.2.2.	Profile Selection.....	16
5.2.3.	Communication Profile	18
5.2.4.	Bluetooth Communication Protocol	18
5.2.5.	Authentication.....	28
5.3.	PCSC API.....	29
5.3.1.	SCardEstablishContext	29
5.3.2.	SCardListReaders	30
5.3.3.	SCardConnect	31
5.3.4.	SCardControl.....	32
5.3.5.	SCardTransmit	34
5.3.6.	SCardDisconnect.....	36
5.3.7.	APDU Flow	37
5.3.8.	Escape Command Flow	38
5.4.	Contact Smart Card Protocol.....	39
5.4.1.	ACOS6-SAM Commands	39
5.5.	Contactless Smart Card Protocol	51
5.5.1.	ATR Generation.....	51
5.5.2.	APDU, Pseudo APDU and Card Native Command	53
5.5.3.	PCSC Pseudo APDU (with Proprietary Extension) for PICC	53
5.5.4.	Pass Through Command	61



5.5.5.	APDU Commands for PCSC 2.0 Part 3 (Version 2.02 or above)	66
5.5.6.	Proprietary Pseudo APDU for PICC	76
5.5.7.	Accessing PCSC-Compliant tags (ISO14443-4)	79
5.5.8.	Accessing MIFARE DESFire tags (ISO 14443-3)	80
5.5.9.	Supported PICC ATR	81
6.0.	Escape Command	84
6.1.	Escape Command for PICC	85
6.1.1.	RF Control [E0 00 00 25 01 ...]	85
6.1.2.	Get PCD/PICC Status [E0 00 00 25 00]	85
6.1.3.	Get Polling/ATR Option [E0 00 00 23 00]	85
6.1.4.	Set Polling/ATR Option [E0 00 00 23 01 ...]	86
6.1.5.	Get PICC Polling Type [E0 00 01 20 00]	87
6.1.6.	Set PICC Polling Type [E0 00 01 20 02 ...]	87
6.1.7.	Get Auto PPS [E0 00 00 24 00]	88
6.1.8.	Set Auto PPS [E0 00 00 24 01 ...]	88
6.1.9.	Read PICC Type [E0 00 00 35 00]	89
6.1.10.	Escape Command for PICC – HID Keyboard	90
6.1.11.	Escape Command for PICC – Card Emulation	96
6.2.	Escape Command for ICC	102
6.2.1.	Get Card Power Configuration [E0 00 00 0B 00]	102
6.2.2.	Set Card Power Configuration [E0 00 00 0B 01 ...]	102
6.3.	Escape Command for Peripheral Control and Other	103
6.3.1.	Get Firmware Version [E0 00 00 18 00]	103
6.3.2.	Get Serial Number [E0 00 00 47 00]	103
6.3.3.	Set S/N in USB Descriptor [E0 00 00 F0]	104
6.3.4.	Set Buzzer Control - Single Time [E0 00 00 28 01 ...]	104
6.3.5.	Set Buzzer Control - Repeatable [E0 00 00 28 03 ...]	105
6.3.6.	Get LED Status [E0 00 00 29 00]	105
6.3.7.	Set LED Control [E0 00 00 29 01 ...]	106
6.3.8.	Get UI Behaviour [E0 00 00 21 00]	106
6.3.9.	Set UI Behaviour [E0 00 00 21 01 ...]	107
6.3.10.	Get BLE UI Behaviour [E0 00 00 4B 01 05]	107
6.3.11.	Set BLE UI Behaviour [E0 00 00 4B 02 05 ...]	108
6.3.12.	Get Standby mode (Sleep Mode) Option [E0 00 00 50 00]	108
6.3.13.	Set Standby Mode (Sleep Mode) Option [E0 00 00 48 ...]	108
6.3.14.	Get Auto Power-Off Option [E0 00 00 0F 00]	109
6.3.15.	Set Auto Power-Off Option [E0 00 00 0F 01 ...]	109
6.3.16.	Get Tx Power Value [E0 00 00 51 00]	110
6.3.17.	Set Tx Power Value [E0 00 00 49 ...]	110
6.3.18.	Get MAC Address [E0 00 00 43 00]	111
6.3.19.	Get BLE Advertising Name [E0 00 00 44 00]	111
6.3.20.	Get Battery Level [E0 00 00 52 00]	112
6.3.21.	Remove BLE Bonding Record [E0 00 00 5B 00]	112
6.3.22.	Read BLE Communication Mode [E0 00 00 77 00]	113
6.3.23.	Set BLE Communication Mode	113
6.3.24.	Customer Master Key Rewrite	114
Appendix A.	NDEF Message	115
Appendix B.	Slot Status and Slot Error	116



List of Figures

Figure 1 : ACR1555U Reader Block Diagram.....	7
Figure 2 : ACR1555U Architecture.....	8
Figure 3 : BLE Protocol Stack	8
Figure 4 : Reader Mode	15
Figure 5 : Bluetooth Connection Flow	16
Figure 6 : Authentication Procedure.....	28
Figure 7 : ACR1555U APDU Flow	37
Figure 8 : ACR1555U Escape Command Flow.....	38
Figure 9 : Transparent Session Flow	66

List of Tables

Table 2 : Symbols and Abbreviations	5
Table 3 : Estimated Battery Lifespan.....	10
Table 4 : USB Interface Wiring	11
Table 5 : Bluetooth Mode LED Behaviour	12
Table 6 : USB Mode LED Behaviour	13
Table 7 : ACR1555U Bluetooth Service	17
Table 8 : ACR1555U Service Handles and UUID Information List.....	17
Table 9 : Command Code Summary	18
Table 10 : Response Code Summary	18
Table 11 : Card Notification Code Summary	19
Table 12 : MIFARE Classic 1K Memory Map	56
Table 13 : MIFARE Classic 4K Memory Map	57
Table 14 : MIFARE Ultralight Memory Map.....	58
Table 15 : Executable Escape Commands without Mutual Authentication	84
Table 15 : NFC Forum Type 2 Tag Memory Map (2000 bytes)	96
Table 16 : FeliCa Memory Map (160 bytes)	97
Table 17 : Slot Status register	116
Table 18 : Slot error register when bmCommandStatus = 1	117



1.0. Introduction

The ACR1555U NFC Bluetooth® Reader is compliant to ISO 14443 Parts 1-4, ISO 18092 and supporting contactless cards, MIFARE® cards, FeliCa™ cards, ISO 7816 Class A, B, and C (5 V, 3 V and 1.8 V) SAM Cards and NFC tags etc.

The reader supports Bluetooth® Standard 5.2, single-mode operation. It is also a USB Type-C device and is compatible with various Operating Systems, such as iOS, Android™, Linux®, MacOS and Windows® Platforms.

For power supply, the ACR1555U provides Li-ion batteries with 450mAh 3.7V. It also includes 3 LEDs and a buzzer to show the device's operation status, as well as 2 buttons to control both battery, device status and Bluetooth® status respectively.

1.1. ACR1555U-A1 Version

Revision ⁽¹⁾	Date Released	Modification
REV 1.03	Nov 2024	<ul style="list-style-type: none"> Initial release Compatible with Reference Manual V1.10 or earlier
REV 1.07	Nov 2025	<ul style="list-style-type: none"> Extended battery life during working mode Reduced battery drain when powered off Enhanced USB charging protection Updated Reference Manual to V1.21

Table 1: History of modification.

¹ The revision number can be found by opening the back cover of the reader.

1.2. Symbols and Abbreviations

Abbreviation	Description
ATR	Attribute Request and Attribute Response
DEP	Data Exchange Protocol Request and Data Exchange Protocol Response
DSL	Deselect Request and Deselect Response
PSL	Parameter Selection Request and Parameter Selection Response
RLS	Release Request and Release Response
WUP	Wakeup Request and Wakeup Response
DID	Device ID
BS	Sending bit duration
BR	Receiving bit duration
PP	Protocol Parameters

Table 2: Symbols and Abbreviations



2.0. Features

- USB Full Speed Interface
- Bluetooth Interface
- CCID-compliant
- Smart Card Reader:
 - Contactless Interface:
 - Support Read/Write speed of up to 26kbps ISO 15693 & 848 kbps (ISO 14443) card types
 - Built-in antenna for contactless tag access, with card reading distance of up to 50 mm (depending on tag type)
 - Supports ISO 14443 Part 4 Type A and B cards, MIFARE® series, FeliCa, and all 5 types of NFC (ISO/IEC 18092) tags
 - Built-in anti-collision feature
 - Supports extended APDU (max. 64 KB)
 - SAM Interface:
 - Supports ISO 7816 Class A (SAM card slot x 1)
- Application Programming Interface:
 - Supports PC/SC and CT-API (through wrapper on top of PC/SC)
- Built-in Peripherals:
 - Three user-controllable LEDs (Blue, Yellow and Red & Green Bi-colour LED)
 - User-controllable buzzer
 - Buttons to control both Power on/off and Bluetooth® status
- USB Firmware Upgradability¹
- Supports Android™ 4.3 and later²
- Supports iOS and iPadOS 12 or above³
- Compliant with the following standards:
 - IEC/EN 62368
 - CE
 - UKCA
 - FCC
 - VCCI
 - RoHS
 - REACH
 - Bluetooth® BQB
 - TELEC (Japan)
 - Microsoft® WHQL
 - KCC (Korea)
 - ISO 14443
 - ISO 15693
 - ISO 7816
 - PC/SC
 - CCID
 - WEEE

¹ Applicable under PC-linked mode

² Uses an ACS-defined Android Library

³ Uses an ACS-defined iOS or iPadOS Library

3.0. ACR1555U Architecture

3.1. Reader Block Diagram

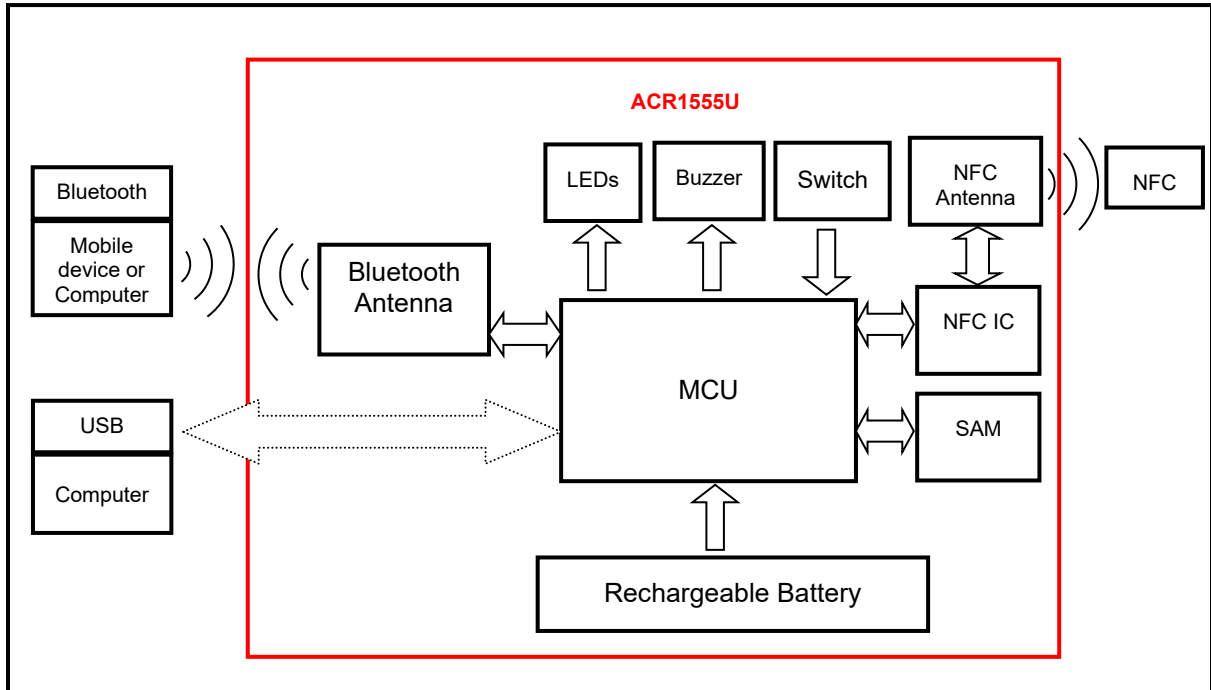

Figure 1: ACR1555U Reader Block Diagram

3.2. Communication between PC/SC driver and PICC and SAM

The protocol used between the ACR1555U and the PC is CCID. All communications between the PICC and SAM are PC/SC-compliant.

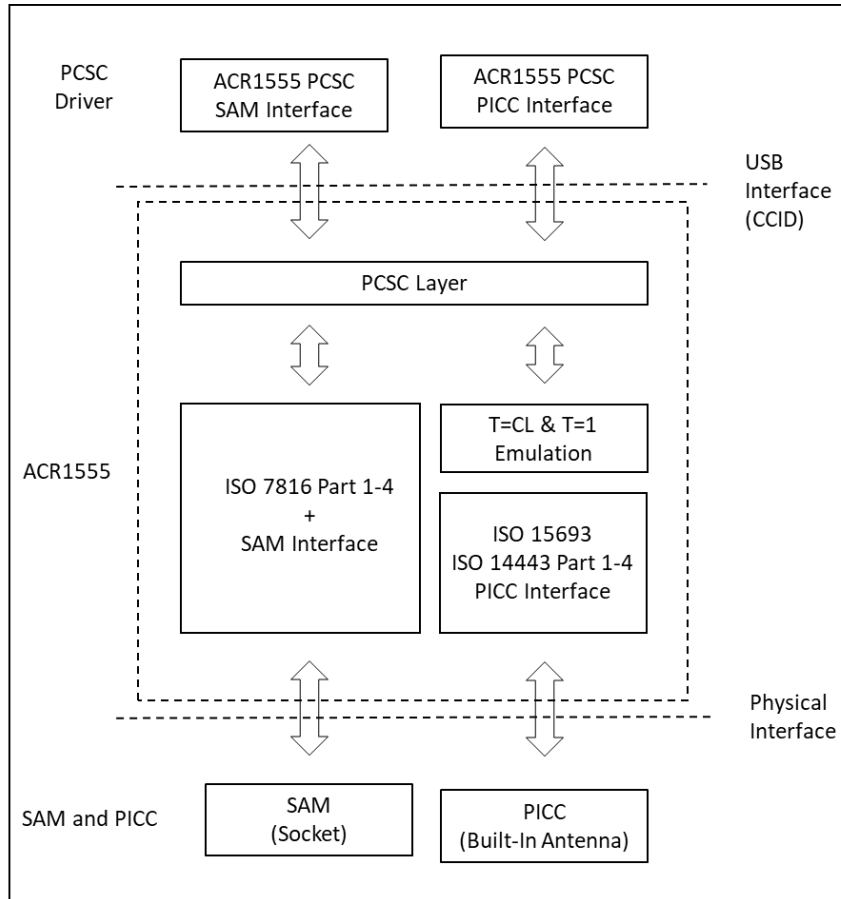

Figure 2: ACR1555U Architecture

Bluetooth low energy protocol stack architecture is show as follow:

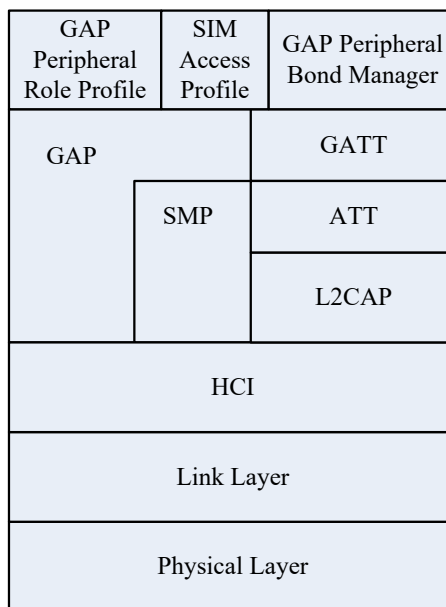

Figure 3: BLE Protocol Stack



4.0. Hardware Design

4.1. Battery

The ACR1555U is powered by a rechargeable Lithium-ion battery with a capacity of 450 mAh.

4.1.1. Battery Charging and usage guideline

Once the battery of the ACR1555U is depleted, it can be recharged while the device is OFF, or during USB or Bluetooth operation, as long as it is connected to a power source.

Charging the Battery

- **Use the Official USB Cable:**
Always charge the ACR1555 using the official USB cable. Using incompatible charging accessories may cause malfunctions or damage.
- **Recommended Charger:**
For optimal safety and performance, use a single-port charger with a 5V, 500mA output.
- **Initial Charging:**
Fully charge the device for the first time.
- **Regular Charging:**
The battery will slowly discharge even when not in use. Recharge before each use to ensure your ACR1555 is always ready.
- **After Charging:**
Disconnect the charger from the outlet or unplug the USB cable from the ACR1555 once charging is complete. This helps prolong battery life.

Safety Precautions

- **Water Exposure:**
Keep the ACR1555 away from water and moisture. The device is not water-resistant and exposure to liquids may cause malfunction or permanent damage.
- **Extreme Temperatures:**
Avoid leaving the ACR1555 in hot environments, such as inside a car or in direct sunlight.

Battery Life

- **Usage Effects:**
The lifespan of the battery depends on storage practices, operating conditions, and environmental factors.

Tips: To maximize battery lifespan, avoid overcharging or fully draining the battery. Charge it regularly, even when not fully depleted, and keep your device away from extreme temperatures.



4.1.2. Battery Life

The battery life of the device is subject to variation based on individual usage patterns. Below are the estimated battery life figures for various usage scenarios, measured per full charge:

Mode	Estimated Battery Life
Working Mode	Up to 12 hours * (1)
Standby Mode ⁽³⁾	Up to 17 hours * (2)
OFF Mode	6 months

Table 3: Estimated Battery Lifespan

Note: Actual results may vary depending on the type of smart card used. This estimation is based on configuring the polling card type to ISO 14443A, setting the RF-off interval to 500ms, and using the ACR1555U-A1 REV1.07⁽⁴⁾.

1. **Working Mode:** In Bluetooth mode, continuous operation when standby mode (sleep mode) is disabled.
2. **Standby Mode:** In Bluetooth mode, with the standby mode (sleep) timer set to 60 seconds. Bluetooth remains connected to host.
3. **“Sleep Mode”** has been renamed to **“Standby Mode.”** All features remain the same.
4. The hardware version can be found by opening the back cover of the reader. For more information, please refer to **Chapter 1.1, Table 1: History of Modification.**

4.2. Bluetooth

The ACR1555U supports Bluetooth connectivity, allowing it to connect wirelessly with computers, smartphones, and tablets. It offers two modes of operation over Bluetooth: Reader Mode and HID Keyboard Emulation Mode.

Reader Mode

In reader mode, the ACR1555U functions as a traditional smart card reader. Once connected to a host device via Bluetooth, it communicates directly with smart card applications using standard protocols (such as PC/SC).

HID Keyboard Emulation Mode

In HID (Human Interface Device) keyboard emulation mode, the ACR1555U acts as a standard Bluetooth keyboard. When a card is read, the device transmits the card data as keystrokes to the paired host device.

4.3. USB

The ACR1555U connects to a computer through a USB interface and is fully compliant with the USB standard.

4.3.1. Communication Parameters

The ACR1555U connects to a computer via USB, as specified in the USB 2.0 specification. It operates in full-speed mode, which supports data transfer rates of up to 12 Mbps.

Pin	Signal	Function
1	V _{BUS}	+5 V power supply for the reader
2	D-	Differential signal transmits data between ACR1555U and PC



Pin	Signal	Function
3	D+	Differential signal transmits data between ACR1555U and PC
4	GND	Reference voltage level for power supply

Table 4: USB Interface Wiring

NOTE - In order for the ACR1555U to function properly through USB interface, either **ACS proprietary device driver** or **Microsoft CCID Driver** has to be installed. Please refer to the Device Driver Installation Guide for more detail.

4.3.2. Endpoints

The ACR1555U uses the following endpoints to communicate with the host computer:

Control Endpoint For setup and control purpose

PICC:

EP1 Bulk OUT For command to be sent from host to ACR1555U PICC interface (data packet size is 64 bytes)

EP1 Bulk IN For response to be sent from ACR1555U PICC interface to host (data packet size is 64 bytes)

EP2 Interrupt IN For card status message to be sent from ACR1555U PICC interface to host (data packet size is 8 bytes)

SAM:

EP3 Bulk OUT For command to be sent from host to ACR1555U SAM interface (data packet size is 64 bytes)

EP3 Bulk IN For response to be sent from ACR1555U SAM interface to host (data packet size is 64 bytes)

4.4. Contactless Smart Card Interface

The interface between the ACR1555U and the contactless card follows the specifications of ISO 14443 with certain restrictions or enhancements to increase the practical functionality of the ACR1555U.

4.4.1. Carrier Frequency

The carrier frequency for the ACR1555U is 13.56 MHz.

4.4.2. Card Polling

The ACR1555U automatically polls the contactless cards that are within the field. ISO 14443-4 Type A, ISO 14443-4 Type B, ISO 15693, FeliCa, Topaz, MIFARE series and NFC tags are supported.

4.5. User Interface

4.5.1. LED

The LEDs are used for showing the Bluetooth mode, power and USB mode status. Blue LED showing Bluetooth mode status, Green LED showing device's power status, Red LED showing Battery status, Yellow LED showing PICC status.

Mode	Color	LED Activity	Status
Bluetooth Mode	Blue (LED1)	Off	Reader powered off / Not paired / USB mode
		Fast flash	Waiting for user to confirm Bluetooth pairing
		Flash	Advertising / Waiting for device pairing
		Slow flash (0.2Hz)	Standby mode ⁽¹⁾
		On	Bluetooth connected
	Red (LED2)	Off	Battery fully charged OR powered by USB only Battery > = 30%, no USB supplied
		Slow flash	Low battery (below 30%)
		On	Battery charging
	Orange ⁴ (LED2)	On	Powered on and charging
	Green (LED2)	Off	Device powered off or Standby Mode
		On	Device is powered on
	Yellow (LED3)	Off	RF Power off
		Fast flash	Reading/writing between smart card and reader
		On	Card present, waiting for instruction

Table 5: Bluetooth Mode LED Behaviour

⁽¹⁾ "Sleep Mode" has been renamed to "Standby Mode." All features remain the same.

⁴ Green and Red both turned on



Mode	Color	LED Activity	Status
USB mode	Blue //(LED1)	Off	Reader is in USB mode
	Red //(LED2)	Off	Battery is fully charged Reader is powered by USB only / The voltage of the battery is greater than 3.5 V and no USB powered is being supplied
		Slow flash	Low battery (below 30% battery level)
		On	Battery is charging
	Orange ⁴ (LED2)	On	Device is powered on and charging
	Green (LED2)	Off	Device is powered off
		On	Device is powered on
	Yellow //(LED3)	Off	No card presented, RF Power off
	Yellow //(LED3)	Fast flash	There is reading/writing between the smart card and reader
		On	Card is present and the reader is waiting for instruction
		Off	No card presented, RF Power off

Table 6: USB Mode LED Behaviour

4.5.2. Buzzer

A buzzer is used to show the poll card, Bluetooth connect, Standby and low power event.

Buzzer Activity	Event
One beep	1. Reader has been powered on 2. Card has been detected or removed 3. Switching from USB mode to BLE mode (LONG beep)
Two beeps	Reader powered and is low battery level
Three short beeps	Power off



4.5.3. Key

The ACR1555U is equipped with two buttons: the BLE (Bluetooth Low Energy) button and the Power button.

Key	Condition	Mode	Key Status	Describe
MODE KEY	-	BLE Mode (paring)	Short press	Confirm Bluetooth Bonding
	Plug-in PC USB	USB Mode	Long press	Switch to BLE mode
	Bluetooth not connected	BLE Mode	Long press	Switch to USB mode
POWER KEY	Reader off	Any	Long press	Power ON
	Reader on		Long press	Power OFF
			Standby	Short press

5.0. Software Design

5.1. Reader's Mode selection

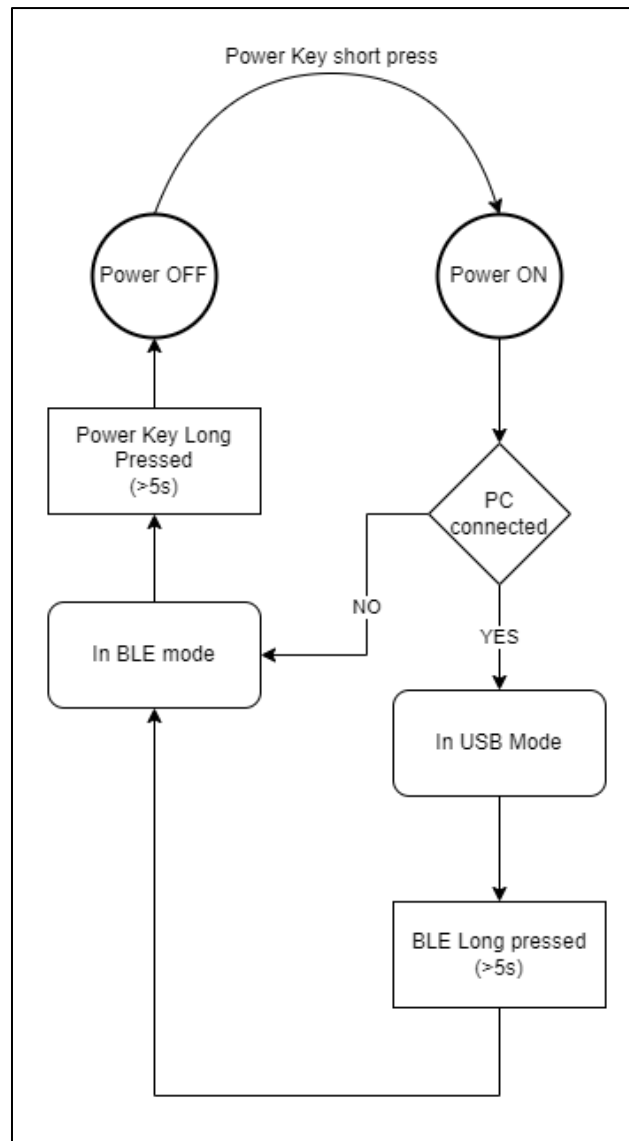

Figure 4: Reader Mode

When powered on, the reader checks the USB port for a 5V connection. If 5V is detected, it initiates USB enumeration. If enumeration is successful, the reader remains in USB mode. If enumeration fails, the reader begins advertising in Bluetooth mode. To switch from Bluetooth mode back to USB mode, the user must turn off the device and power it on again to re-initiate USB enumeration.

5.2. Bluetooth Communication

5.2.1. Bluetooth Connection Flow

The program flow of the Bluetooth connection is shown below:

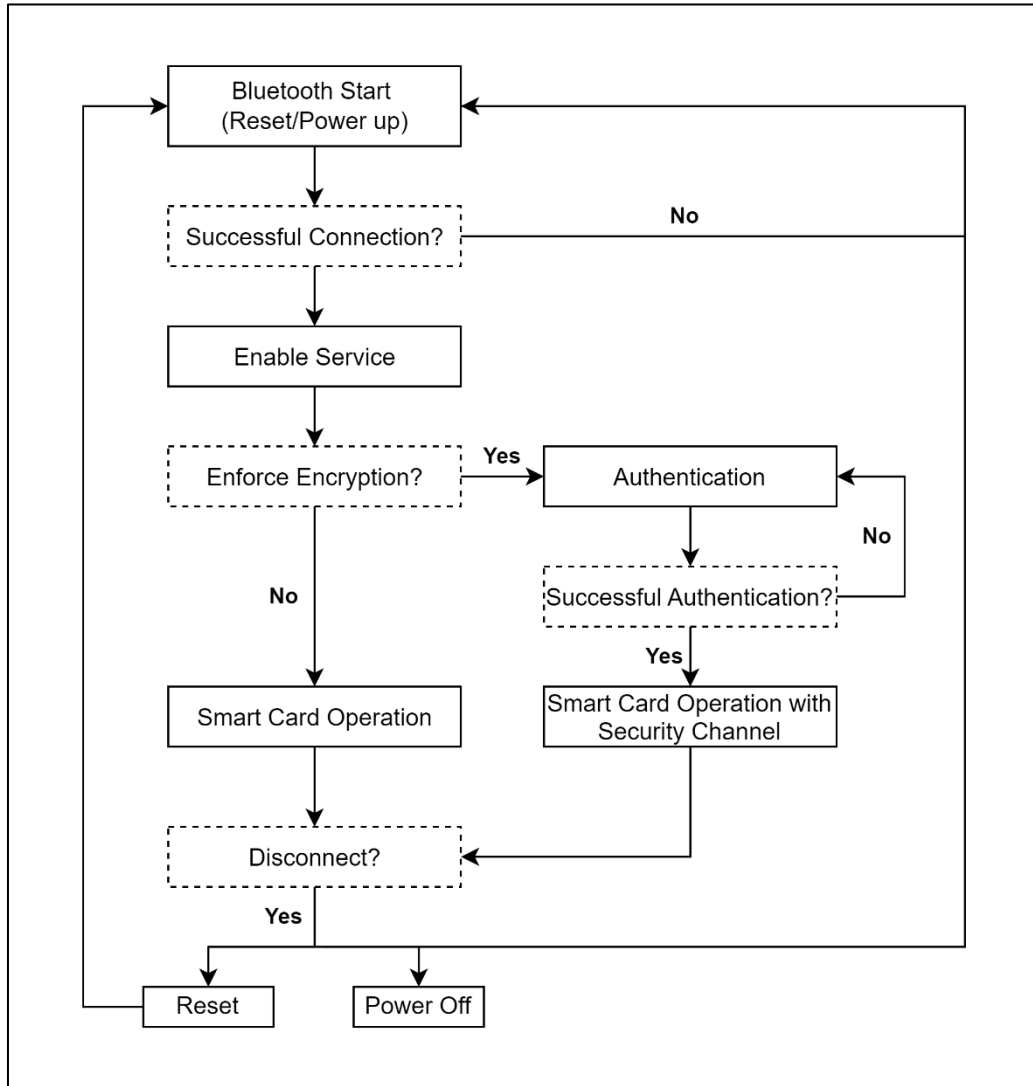

Figure 5: Bluetooth Connection Flow

5.2.2. Profile Selection

The ACR1555U is a smart card reader that is designed to use Bluetooth technology as an interface to transmit data. A customized service called Commands Communication with three pipes is used: the first pipe is used for command request, the second pipe is for command response, and the third pipe is for card notification.

Also, the reader's current power consumption is significantly greater when the reader is operating in Bluetooth mode, hence, a standard battery service is used to notify the paired device about the current battery status. When there is a change in the battery status, the reader will notify the paired device through a specific pipe. To simplify, the battery levels are divided into three groups: sufficient battery (≥ 3.4 V), low battery (< 3.4 V and ≥ 3.1 V), and no battery (< 3.1 V).

Finally, to provide more reader information to the user, a customized Device Information service is added. This can only be read manually, or by an application request. The characteristics include Model Number, Serial Number, Firmware Revision, and Manufacturer Name.



Service	UUID	Pipe
Smart Card	00003971-817C-48DF-8DB2-476A8134EDE0	Commands Request
	00003972-817C-48DF-8DB2-476A8134EDE0	Commands Response
	00003973-817C-48DF-8DB2-476A8134EDE0	Card Notification
Battery	2A19	Battery Level
Device Information	2A23	System ID
	2A24	Model Number
	2A25	Serial Number
	2A26	Firmware Revision
	2A27	Hardware Revision
	2A29	Manufacturer Name

Table 7: ACR1555U Bluetooth Service

Attribute Name	UUID	Handle
DeviceName	2A00	06h
Send(Reader → Paired device)	00003971-817C-48DF-8DB2-476A8134EDE0	28h
Receive(Paired device → Reader)	00003972-817C-48DF-8DB2-476A8134EDE0	2Bh
Card Notification(Reader → Paired device)	00003973-817C-48DF-8DB2-476A8134EDE0	2Fh
ABatteryLevel	2A19	20h
Manufacturer	2A29	19h
SerialNumber	2A25	11h
FW_Version	2A26	13h
ModelNumber	2A24	0Fh

Table 8: ACR1555U Service Handles and UUID Information List



5.2.3. Communication Profile

The communication profile should be:

Start byte + Slot + Len + *Reserved* (1 byte) + Datablock + Checksum + Stop byte

Field	Size (bytes)	Description
Start byte	1	Value: 55h
Slot	1	Slot 00h: PICC, Slot 01h SAM
Len	2	Len means the number of bytes in the Datablock field
Mutual authentication	1	0x00 for Plain data and 0x01 for Encrypted data
Host Sequence Number	1	Increase by 1 for new frame send by host
Reader Sequence Number	1	Increase by 1 for new frame send by reader
Datablock	N	Data (Message Body follow CCID)
Checksum	1	XOR values of Slot, Len, Frame Type, Host & Reader Seq, Data Field
Stop byte	1	Value: AAh

5.2.4. Bluetooth Communication Protocol

The ACR1555U communicates to the paired device using the Bluetooth interface with a predefined protocol. The protocol is similar to the formats of the CCID Command Pipe and Response Pipe.

Command	Mode Supported	Sender	Description
62h	Plain text, Authenticated	Paired device	PICC Power On
63h	Plain text, Authenticated	Paired device	PICC Power Off
65h	Plain text, Authenticated	Paired device	Get Card Status
6Fh	Plain text, Authenticated	Paired device	Exchange APDU
6Bh	Plain text, Authenticated	Paired device	Escape Commands
61h	Plain text, Authenticated	Paired device	Set Parameters

Table 9: Command Code Summary

Command	Mode Supported	Sender	Description
80h	Plain text, Authenticated	Reader	Response to Data Block
81h	Plain text, Authenticated	Reader	Response to Slot Status
82h	Plain text, Authenticated	Reader	Response to Parameters
83h	Plain text, Authenticated	Reader	Response to Escape Command
53h	Plain text, Authenticated	Reader	Response to Error

Table 10: Response Code Summary



Command	Mode Supported	Sender	Description
50h	Plain text, Authenticated	Reader	Notify Card Status
52h	Plain text, Authenticated	Reader	Notify Enter Standby mode ⁽¹⁾ (Sleep Mode)

Table 11: Card Notification Code Summary

⁽¹⁾ “Sleep Mode” has been renamed to “Standby Mode.” All features remain the same.

5.2.4.1. PC_to_RDR_IccPowerOn

Activate the card slot and return ATR from the card.

Offset	Field	Size	Value	Description
0	bMessageType	1	62h	-
1	dwLength	4	00 00 00 00h	Size of extra bytes of this message
2	bSlot	1	00~01h	Identifies the slot number for this command 00h: PICC 01h: SAM
5	bSeq	1	00-FFh	Sequence number for command
6	bPowerSelect	1	00~02h	Voltage that is applied to the ICC 00h – Automatic Voltage Selection 01h – 5 volts 02h – 3 volts
7	abRFU	2	00 00h	Reserved for future use

The response to this message is the RDR_to_PC_DataBlock message and the data returned is the Answer To Reset (ATR) data.

5.2.4.2. PC_to_RDR_IccPowerOff

Deactivate the card slot.

Offset	Field	Size	Value	Description
0	bMessageType	1	63h	-
1	dwLength	4	00 00 00 00h	Size of extra bytes of this message
5	bSlot	1	00~01h	Identifies the slot number for this command 00h: PICC 01h: SAM
6	bSeq	1	00~FFh	Sequence number for command
7	abRFU	3	00 00 00h	Reserved for future use

The response to this message is the RDR_to_PC_SlotStatus message.

5.2.4.3. PC_to_RDR_GetSlotStatus

Get current status of the slot.



Offset	Field	Size	Value	Description
0	bMessageType	1	65h	-
1	dwLength	4	00 00 00 00h	Size of extra bytes of this message
5	bSlot	1	00~01h	Identifies the slot number for this command 00h: PICC 01h: SAM
6	bSeq	1	00~FFh	Sequence number for command
7	abRFU	3	00 00 00h	Reserved for future use

The response to this message is the RDR_to_PC_SlotStatus message.

5.2.4.4. PC_to_RDR_XfrBlock

Transfer data block to the ICC.

Offset	Field	Size	Value	Description
0	bMessageType	1	6Fh	-
1	dwLength	4	00 00 00 00 ~ 00 00 01 E7h	Size of abData field of this message Fields are stored in little endian.
5	bSlot	1	00~01h	Identifies the slot number for this command 00h: PICC 01h: SAM
6	bSeq	1	00~FFh	Sequence number for command
7	abRFU	1	00h	Reserved for Future Use
8	wLevelParameter	2	-	Fields are stored in little endian. Short APDU level, RFU, = 0000h Extended APDU level: indicates if APDU begins or ends in this command: 0000h the command APDU begins and ends with this command, 0001h the command APDU begins with this command, and continue in the next PC_to_RDR_XfrBlock, 0002h this abData field continues a command APDU and ends the APDU command, 0003h the abData field continues a command APDU and another block is to follow, 0010h empty abData field, continuation of response APDU is expected in the next RDR_to_PC_DataBlock.



Offset	Field	Size	Value	Description
10	abData	Byte array	-	Data block sent to the CCID. Data is sent "as is" to the ICC (TPDU exchange level)

The response to this message is the RDR_to_PC_DataBlock message.

5.2.4.5. PC_to_RDR_Escape

Access extended features.

Offset	Field	Size	Value	Description
0	bMessageType	1	6Bh	-
1	dwLength	4	00 00 00 00 ~ 00 00 00 FFh	Size of abData field of this message. Fields are stored in little endian.
5	bSlot	1	00h~01h	Identifies the slot number for this command 00h: PICC 01h: SAM
6	bSeq	1	00~FFh	Sequence number for command
7	abRFU	3	00 00 00h	Reserved for Future Use
10	abData	Byte array	-	data block sent to the CCID

The response to this command message is the RDR_to_PC_Escape response message

5.2.4.6. PC_to_RDR_SetParameters

Set slot parameters.

Offset	Field	Size	Value	Description
0	bMessageType	1	61h	-
1	dwLength	4	00 00 00 05h or 00 00 00 07h	Size of abProtocolDataStructure field of this message. Fields are stored in little endian.
5	bSlot	1	00~01h	Identifies the slot number for this command 00h: PICC 01h: SAM
6	bSeq	1	00~FFh	Sequence number for command



Offset	Field	Size	Value	Description
7	bProtocolNum	1	00~01h	Specifies what protocol data structure follows. 00h = Structure for protocol T=0 01h = Structure for protocol T=1 The following values are reserved for future use. 80h = Structure for 2-wire protocol 81h = Structure for 3-wire protocol 82h = Structure for I2C protocol
8	abRFU	2	00 00h	Reserved for future use
10	abProtocolDataStructure	Byte array	-	Protocol Data Structure

Protocol Data Structure for Protocol T=0 (dwLength=00 00 00 05h)

Offset	Field	Size	Value	Description
10	bmFindexDindex	1		B7-4 – FI – Index into the table 7 in ISO/IEC 7816-3:1997 selecting a clock rate conversion factor B3-0 – DI - Index into the table 8 in ISO/IEC 7816-3:1997 selecting a baud rate conversion factor
11	bmTCKKST0	1	00h, 02h	B0 – 0b, B7-2 – 000000b B1 – Convention used (b1=0 for direct, b1=1 for inverse) Note: The CCID ignores this bit.
12	bGuardTimeT0	1	00~FFh	Extra Guardtime between two characters. Add 0 to 254 etu to the normal guardtime of 12etu. FFh is the same as 00h.
13	bWaitingIntegerT0	1	00~FFh	WI for T=0 used to define WWT
14	bClockStop	1	00~03h	ICC Clock Stop Support 00h = Stopping the Clock is not allowed 01h = Stop with Clock signal Low 02h = Stop with Clock signal High 03h = Stop with Clock either High or Low

Protocol Data Structure for Protocol T=1 (dwLength=00000007h)

Offset	Field	Size	Value	Description
10	bmFindexDindex	1		B7-4 – FI – Index into the table 7 in ISO/IEC 7816-3:1997 selecting a clock rate conversion factor B3-0 – DI - Index into the table 8 in ISO/IEC 7816-3:1997 selecting a baud rate conversion factor
11	BmTCKKST1	1	10h, 11h, 12h, 13h	B7-2 – 000100b



				B0 – Checksum type (b0=0 for LRC, b0=1 for CRC) B1 – Convention used (b1=0 for direct, b1=1 for inverse) Note: The CCID ignores this bit.
12	BGuardTimeT1	1	00~FFh	Extra Guardtime (0 to 254 etu between two characters). If value is FFh, then guardtime is reduced by 1 etu.
13	BwaitingIntegerT1	1	00~9Fh	B7-4 = BWI values 0-9 valid B3-0 = CWI values 0-Fh valid
14	bClockStop	1	00~03h	ICC Clock Stop Support 00h = Stopping the Clock is not allowed 01h = Stop with Clock signal Low 02h = Stop with Clock signal High 03h = Stop with Clock either High or Low
15	bIFSC	1	00~FEh	Size of negotiated IFSC
16	bNadValue	1	00h	Only support NAD = 00h

The response to this message is the RDR_to_PC_Parameters message



5.2.4.7. RDR_to_PC_DataBlock

This message is sent by ACR1555U in response to PC_to_RDR_IccPowerOn and PC_to_RDR_XfrBlock messages.

Offset	Field	Size	Value	Description
0	bMessageType	1	80h	Indicates that a data block is being sent from the CCID
1	dwLength	4	00 00 00 00 ~ 00 00 01 E7h	Size of abData field of this message. Fields are stored in little endian.
5	bSlot	1	-	Same value as in Bulk-OUT message
6	bSeq	1	-	Same value as in Bulk-OUT message
7	bStatus	1	-	Slot status register as defined in Appendix B
8	bError	1	-	Slot error register as defined in Appendix B
9	bChainParameter	1	-	Short APDU level, RFU = 00h Extended APDU level: 00h – the response APDU begins and ends in this command. 01h – the response APDU begins with this command, and is to continue. 02h – this abData field continues the response APDU and ends the response APDU. 03h – this abData field continues the response APDU and another block is to follow. 10h – empty abData field, continuation of command APDU is expected in the next PC_to_RDR_XfrBlock command.
10	abData	Byte array	-	This field contains the data returned by the CCID



5.2.4.8. RDR_to_PC_SlotStatus

This message is sent by ACR1555U in response to PC_to_RDR_IccPowerOff, and PC_to_RDR_GetSlotStatus.

Offset	Field	Size	Value	Description
0	bMessageType	1	81h	-
1	dwLength	4	00 00 00 00h	Size of extra bytes of this message
5	bSlot	1	-	Same value as in Bulk-OUT message
6	bSeq	1	-	Same value as in Bulk-OUT message
7	bStatus	1	-	Slot status register as defined in Appendix B
8	bError	1	-	Slot error register as defined in Appendix B
9	bClockStatus	1	00~03h	Value = 00h Clock running 01h Clock stopped in state L 02h Clock stopped in state H 03h Clock stopped in an unknown state All other values are RFU.

5.2.4.9. RDR_to_PC_Parameters

This message is sent by ACR1555U in response to PC_to_RDR_GetParameters, PC_to_RDR_ResetParameters and PC_to_RDR_SetParameters messages.

Offset	Field	Size	Value	Description
0	bMessageType	1	82h	-
1	dwLength	4	00 00 00 05h or 00 00 00 07h	Size of abProtocolDataStructure field of this message. Fields are stored in little endian.
5	bSlot	1	-	Same value as in Bulk-OUT message
6	bSeq	1	-	Same value as in Bulk-OUT message
7	bStatus	1	-	Slot status register as defined in Appendix B
8	bError	1	-	Slot error register as defined in Appendix B
9	bProtocolNum	1	00~01h	Specifies what protocol data structure follows. 00h = Structure for protocol T=0 01h = Structure for protocol T=1 The following values are reserved for future use. 80h = Structure for 2-wire protocol 81h = Structure for 3-wire protocol 82h = Structure for I2C protocol



10	abProtocolDataStructure	Byte array	-	Protocol Data Structure as summarized in 5.2.4.6 .
----	-------------------------	------------	---	--

5.2.4.10. RDR_to_PC_Escape

This message is sent by ACR1555U in response to PC_to_RDR_Escape messages

Offset	Field	Size	Value	Description
0	bMessageType	1	83h	-
1	dwLength	4	00 00 00 00 ~ 00 00 00 FFh	Size of abData field of this message. Fields are stored in little endian.
5	bSlot	1	-	Same value as in Bulk-OUT message
6	bSeq	1	-	Same value as in Bulk-OUT message
7	bStatus	1	-	Slot status register as defined in Appendix B
8	bError	1	-	Slot error register as defined in Appendix B
9	bChainParameter	1	00h	RFU
10	abData	Byte array	-	Data send from CCID

5.2.4.11. RDR_to_PC_Error

This message returns an Error message if the device received an incorrect command.

Offset	Field	Size	Value	Description
0	bMessageType	1	53h	-
1	dwLength	4	00 00 00 00h	Size of extra data this message.
5	bSlot	1	-	Same value as in Bulk-OUT message
6	bSeq	1	-	Same value as in Bulk-OUT message
7	bStatus	1	-	Slot status register as defined in Appendix B
8	bErrorCode	1	-	01h = Checksum error 02h = RFU 03h = Command error 04h = Unauthorized 05h = Undefined error 06h = Receive data error 07h = Receive data length error 08h = Exceeded authentication retry error
9	abRFU	1	00h	RFU



5.2.4.12. RDR_to_PC_NotifySlotChange

This message notifies the card status by the reader.

Offset	Field	Size	Value	Description
0	bMessageType	1	50h	-
1	bmSlotICCState	1	-	Status: 02h = PICC absent 03h = PICC present

5.2.4.13. RDR_to_PC_Sleep

This message notifies the Standby mode⁽¹⁾ (Sleep Mode) status by the reader.

Offset	Field	Size	Value	Description
0	bMessageType	1	52h	-
1	bParam	1	00h	RFU

⁽¹⁾“Sleep Mode” has been renamed to “Standby Mode.” All features remain the same.

5.2.5. Authentication

If the enforce encryption is enabled. Before any sensitive data can be loaded into the ACR1555U, the data processing server must be authenticated by the ACR1555U for the privilege to modify the secured data inside reader. In the ACR1555U, a mutual authentication method is used.

For better illustration, please refer to the figure below (the picture below has omitted the bridging device for simplicity and better illustration):

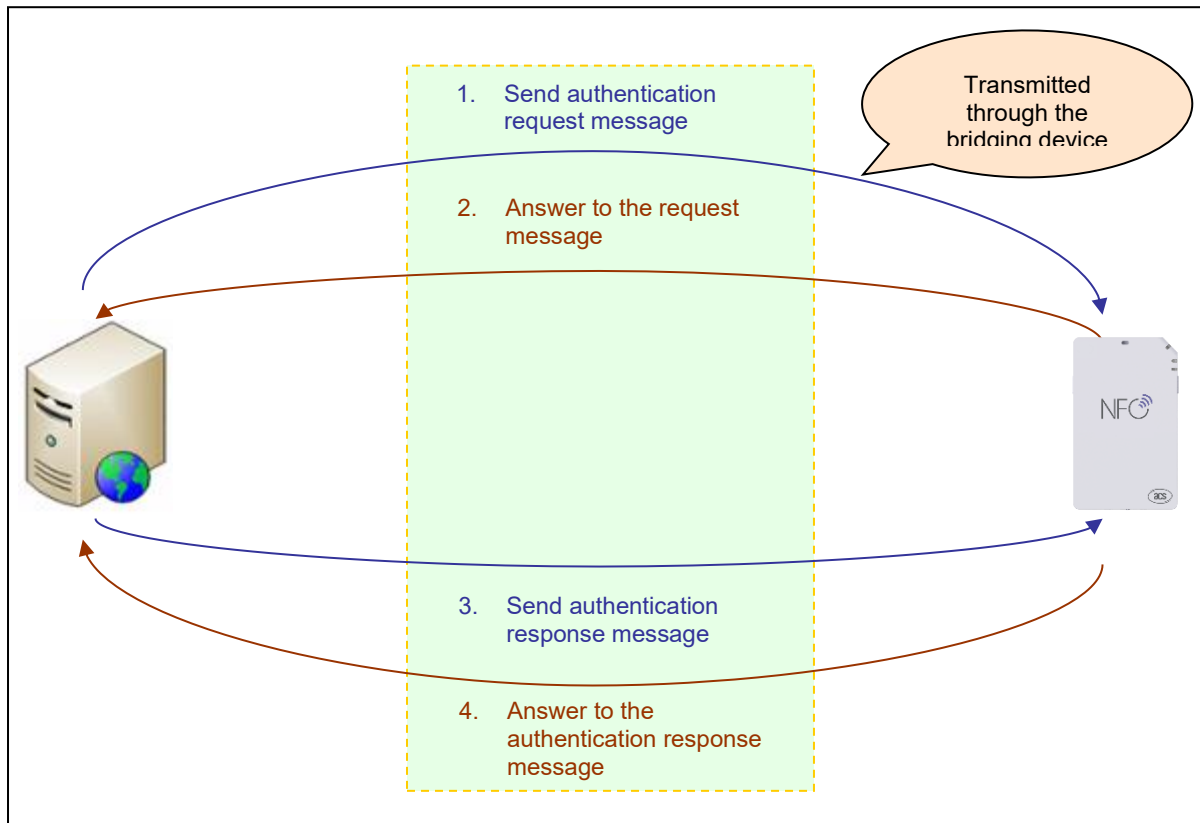

Figure 6: Authentication Procedure

After successful authentication, a 16-byte Session Key is generated in both the ACR1555U and the data server.

Default Customer Master Key (Hex): **41 43 52 31 35 35 35 55 2D 41 31 20 41 75 74 68**

Important:

If you enter incorrect authentication keys, the reader will become permanently unusable. Please ensure you enter the correct keys. Double-check your input before submitting.

For more detailed information, please refer to Developer's Guide for Mutual Authentication And Secure Data Exchange. you may contact an ACS sales representative,



5.3. PCSC API

This section will describe some of the PCSC API for application programming usage. For more details, please refer to Microsoft MSDN Library or PCSC workgroup.

5.3.1. SCardEstablishContext

The SCardEstablishContext function establishes the resource manager context within which database operations are performed.

Refer to: <http://msdn.microsoft.com/en-us/library/windows/desktop/aa379479%28v=vs.85%29.aspx>

This function should be performed first before any other PCSC operation.

Example:

```
#define SCARD_SCOPE_USER 0

SCARDCONTEXT hContext;
int retCode;
void main ()
{
    // To establish the resource manager context and assign it to
    "hContext"
    retCode = SCardEstablishContext(SCARD_SCOPE_USER,
                                   NULL,
                                   NULL,
                                   &hContext);
    if (retCode != SCARD_S_SUCCESS)
    {
        // Establishing resource manager context failed
    }
    else
    {
        // Establishing resource manager context successful
        // Further PCSC operation can be performed
    }
}
```



5.3.2. SCardListReaders

The SCardListReaders function provides the list of readers within a set of named reader groups, eliminating duplicates.

The caller supplies a list of reader groups, and receives the list of readers within the named groups. Unrecognized group names are ignored. This function only returns readers within the named groups that are currently attached to the system and available for use.

Refer to: <http://msdn.microsoft.com/en-us/library/windows/desktop/aa379793%28v=vs.85%29.aspx>

Example:

```
#define SCARD_SCOPE_USER 0

SCARDCONTEXT hContext; // Resource manager context
int retCode;
char readerName [256]; // List reader name

void main ()
{
    // To establish the resource manager context and assign to "hContext"
    retCode = SCardEstablishContext(SCARD_SCOPE_USER,
        NULL,
        NULL,
        &hContext);
    if (retCode != SCARD_S_SUCCESS)
    {
        // Establishing resource manager context failed
    }
    else
    {
        // Establishing resource manager context successful
        // List the available reader which can be used in the system
        retCode = SCardListReaders (hContext,
            NULL,
            readerName,
            &size);
        if (retCode != SCARD_S_SUCCESS)
        {
            // Listing reader fail
        }
        if (readerName == NULL)
        {
            // No reader available
        }
        else
        {
            // Reader listed
        }
    }
}
}
```



5.3.3. SCardConnect

The SCardConnect function establishes a connection (using a specific resource manager context) between the calling application and a smart card contained by a specific reader. If no card exists in the specified reader, an error is returned.

Refer to: <http://msdn.microsoft.com/en-us/library/windows/desktop/aa379473%28v=vs.85%29.aspx>

Example:

```
#define SCARD_SCOPE_USER 0

SCARDCONTEXT      hContext;          // Resource manager context
SCARDHANDLE       hCard;             // Card context handle
unsigned long     dwActProtocol;     // Establish active protocol
int               retCode;
char              readerName [256]; // List reader name
char              rName [256];      // Reader name for connection

void main ()
{
    ...
    if (readerName == NULL)
    {
        // No reader available
    }
    else
    {
        // Reader listed
        rName = "ACS ACR1555 1S CL Reader PICC 0"; // Depends on what
                                                    // reader be used
                                                    // Should connect to
                                                    // PICC interface

        retCode = SCardConnect(hContext,
                                rName,
                                SCARD_SHARE_SHARED,
                                SCARD_PROTOCOL_T1,
                                &hCard,
                                &dwActProtocol);
        if (retCode != SCARD_S_SUCCESS)
        {
            // Connection failed (May be because of incorrect reader
            // name, or no card was detected)
        }
        else
        {
            // Connection successful
        }
    }
}
```



5.3.4. SCardControl

The SCardControl function gives you direct control of the reader. You can call it any time after a successful call to SCardConnect and before a successful call to SCardDisconnect. The effect on the state of the reader depends on the control code.

Refer to: <http://msdn.microsoft.com/en-us/library/windows/desktop/aa379474%28v=vs.85%29.aspx>

Note: Commands from **Escape Command** use this API for sending.

Example:

```
#define SCARD_SCOPE_USER 0

#define EscapeCommand 0x310000 + 3500*4
SCARDCONTEXT hContext; // Resource manager context
SCARDHANDLE hCard; // Card context handle
unsigned long dwActProtocol; // Established active protocol
int retCode;
char readerName [256]; // Lists reader name
char rName [256]; // Reader name for connection
BYTE SendBuff[262], // APDU command buffer
RecvBuff[262]; // APDU response buffer
BYTE FWVersion [20], // For storing firmware
version message
BYTE ResponseData[50]; // For storing card response
DWORD SendLen, // APDU command length
RecvLen; // APDU response length

void main ()
{
    ...
    rName = "ACS ACR1555 1S CL Reader PICC 0"; // Depends on what
reader will be used
// Should connect to
PICC interface

    retCode = SCardConnect(hContext,
        rName,
        SCARD_SHARE_DIRECT,
        SCARD_PROTOCOL_T0| SCARD_PROTOCOL_T1,
        &hCard,
        &dwActProtocol);
    if (retCode != SCARD_S_SUCCESS)
    {
        // Connection failed (may be because of incorrect reader
name, or no card was detected)
    }
    else
    {
        // Connection successful
        RecvLen = 262;
        // Get firmware version
        SendBuff[0] = 0xE0;
        SendBuff[1] = 0x00;
        SendBuff[2] = 0x00;
        SendBuff[3] = 0x18;
        SendBuff[4] = 0x00;
    }
}
```



```
SendLen = 5;
retCode = SCardControl ( hCard,
    EscapeCommand,
    SendBuff,
    SendLen,
    RecvBuff,
    RecvLen,
    &RecvLen);
if (retCode != SCARD_S_SUCCESS)
{
    // APDU sending failed
    return;
}
else
{
    // APDU sending successful
    // The RecvBuff stores the firmware version message.
    for (int i=0;i< RecvLen-5;i++)
    {
        FWVersion[i] = RecvBuff [5+i];
    }
}
// Connection successful
RecvLen = 262;

// Turn Green LED on, turn Red LED off
SendBuff[0] = 0xE0;
SendBuff[1] = 0x00;
SendBuff[2] = 0x00;
SendBuff[3] = 0x29;
SendBuff[4] = 0x01;
SendBuff[5] = 0x02; // Green LED On, Red LED off
SendLen = 6;
retCode = SCardControl ( hCard,
    EscapeCommand,
    SendBuff,
    SendLen,
    RecvBuff,
    RecvLen,
    &RecvLen);
if (retCode != SCARD_S_SUCCESS)
{
    // APDU sending failed
    return;
}
else
{
    // APDU sending success
}
```



5.3.5. SCardTransmit

The SCardTransmit function sends a service request to the smart card and expects to receive data back from the card.

Refer to: <http://msdn.microsoft.com/en-us/library/windows/desktop/aa379804%28v=vs.85%29.aspx>

Note: APDU Commands (i.e. the commands sent to connected card, **PCSC Pseudo APDU (with Proprietary Extension) for PICC**, and **Proprietary Pseudo APDU for PICC**) use this API for sending.

Example:

```
#define SCARD_SCOPE_USER      0

SCARDCONTEXT      hContext;          // Resource manager context
SCARDHANDLE        hCard;            // Card context handle
unsigned long      dwActProtocol;    // Established active protocol
int                retCode;
char               readerName [256]; // List reader name
char               rName [256];     // Reader name for connect
BYTE               SendBuff[262];   // APDU command buffer
BYTE               RecvBuff[262];   // APDU response buffer
BYTE               CardID [8],      // For storing the FeliCa IDM/
                                MIFARE UID
BYTE               ResponseData[50]; // For storing card response
DWORD              SendLen,         // APDU command length
DWORD              RecvLen;         // APDU response length
SCARD_IO_REQUEST  ioRequest;

void main ()
{
    ...
    rName = "ACS ACR1555 1S CL Reader PICC 0"; // Depends on what
                                                // reader should be used
                                                // Should connect to PICC
                                                // interface

    retCode = SCardConnect(hContext,
                           rName,
                           SCARD_SHARE_SHARED,
                           SCARD_PROTOCOL_T1,
                           &hCard,
                           &dwActProtocol);
    if (retCode != SCARD_S_SUCCESS)
    {
        // Connection failed (May be because of incorrect reader
        // name, or no card was detected)
    }
    else
    {
        // Connection successful
        ioRequest.dwProtocol = dwActProtocol;
        ioRequest.cbPciLength = sizeof(SCARD_IO_REQUEST);
        RecvLen = 262;
    }
}
```



```
// Get MIFARE UID/ FeliCa IDM
SendBuff[0] = 0xFF;
SendBuff[1] = 0xCA;
SendBuff[2] = 0x00;
SendBuff[3] = 0x00;
SendBuff[4] = 0x00;
SendLen = 5;
retCode = SCardTransmit( hCard,
                        &ioRequest,
                        SendBuff,
                        SendLen,
                        NULL,
                        RecvBuff,
                        &RecvLen);

if (retCode != SCARD_S_SUCCESS)
{
    // APDU sending failed
    return;
}
else
{
    // APDU sending successful
    // The RecvBuff stores the IDM for FeliCa / the UID for
    MIFARE.
    // Copy the content for further FeliCa access
    for (int i=0;i< RecvLen-2;i++)
    {
        CardID [i] = RecvBuff[i];
    }
}
}
```



5.3.6. SCardDisconnect

The **SCardDisconnect** function terminates a connection previously opened between the calling application and a *smart card* in the target *reader*.

Refer to: <http://msdn.microsoft.com/en-us/library/windows/desktop/aa379475%28v=vs.85%29.aspx>

This function is used to end the PCSC Operation.

Example:

```
#define SCARD_SCOPE_USER 0

SCARDCONTEXT      hContext;          // Resource manager context
SCARDHANDLE       hCard;            // Card context handle
unsigned long     dwActProtocol;    // Established active protocol
int               retCode;

void main ()
{
    ...
    // Connection successful
    ...
    retCode = SCardDisconnect(hCard, SCARD_RESET_CARD);
    if (retCode != SCARD_S_SUCCESS)
    {
        // Disconnection failed
    }
    else
    {
        // Disconnection successful
    }
}
}
```

5.3.7. APDU Flow

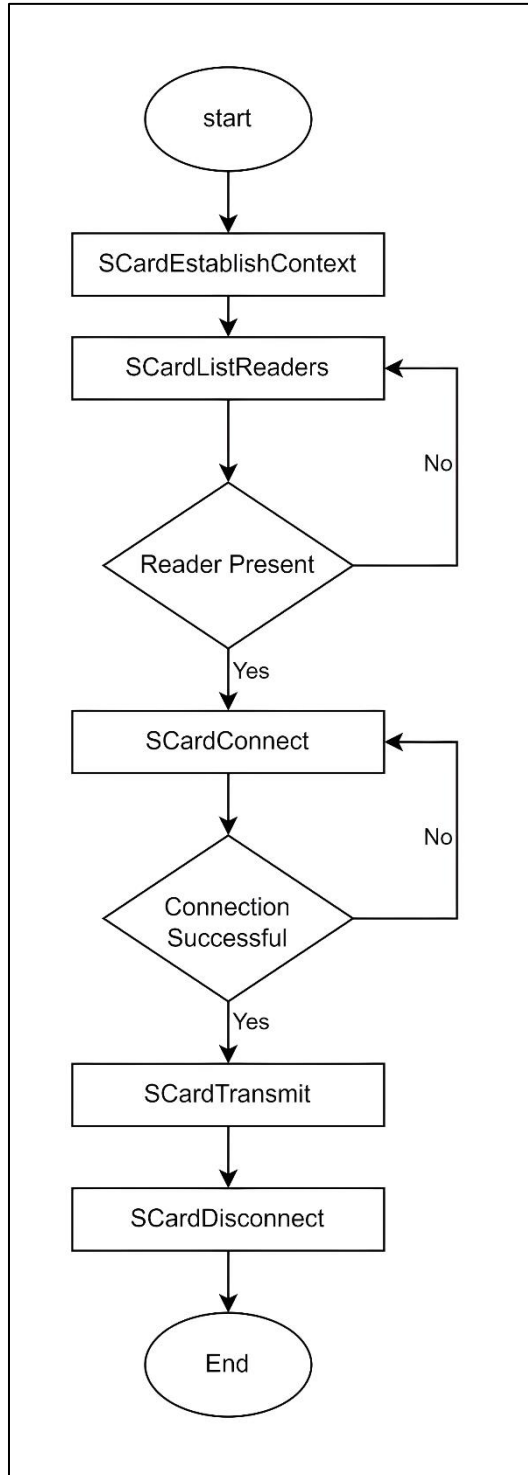

Figure 7: ACR1555U APDU Flow

5.3.8. Escape Command Flow

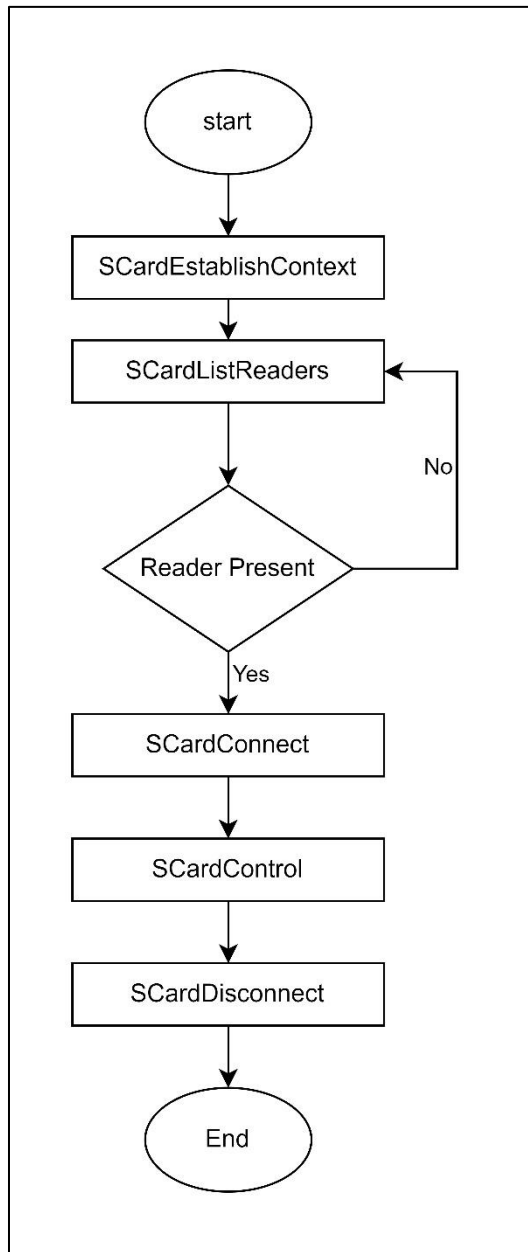

Figure 8: ACR1555U Escape Command Flow



5.4. Contact Smart Card Protocol

5.4.1. ACOS6-SAM Commands

This section contains SAM-specific commands. CCID Host could send Card Native Command or APDU to the Reader by using CCID Message PC_to_RDR_XfrBlock (corresponding to SCardTransmit() in PCSC API).

Note: Please note that the ACOS6-SAM component is only included in the ACR1555U SDK package bundled with the reader. It is not part of the standard retail version of the reader. For complete information on ACOS6-SAM Commands and Scenarios, please contact an ACS representative for a copy of the ACOS6-SAM Reference Manual.

5.4.1.1. Generate Key

This command is used to generate a diversified key to load into the ACOS3/6 card or other cards from deviation data such as a client card serial number. This command is catered for client card issuance purposes.

APDU	Description
CLA	80h
INS	88h
	00h Generate 8 Byte Key
P1	01h Generate 16 Byte Key
	02h Generate 24 Byte Key
P2	Key index of Master Key to generate Derived Key
P3	08h
Data	Input Data

Specific Response Status Bytes

SW1 SW2	Description
69 86h	No DF selected
6A 86h	Invalid P1 or P2
67 00h	Incorrect P3, must be 08h
6A 83h	Referenced key record not found in EF2
69 81h	Invalid EF2 (record size, file type, etc.)
6A 88h	EF2 not found
62 83h	Current DF is blocked; EF2 is blocked
69 83h	Usage counter is zero.
69 82h	Security condition not satisfied
6A 87h	Referenced Master Key is not capable of 3-DES encryption
61 08h	Command completed, issue GET RESPONSE to get the result



5.4.1.2. Diversify (or load) Key Data

This command prepares the SAM card to perform ciphering operations by diversifying and loading the key. It takes the serial number and CBC initial vector as command data input.

APDU	Description																																																																																	
CLA	80h																																																																																	
INS	72h																																																																																	
	<table border="1"> <thead> <tr> <th>b7</th> <th>b6</th> <th>b5</th> <th>b4</th> <th>b3</th> <th>b2</th> <th>b1</th> <th>b0</th> <th>Description</th> </tr> </thead> <tbody> <tr> <td>-</td> <td>0</td> <td>0</td> <td>0</td> <td>0</td> <td>0</td> <td>0</td> <td>1</td> <td>Secret Code (Sc)</td> </tr> <tr> <td>-</td> <td>0</td> <td>0</td> <td>0</td> <td>0</td> <td>0</td> <td>1</td> <td>0</td> <td>Account Key (K_{Acct})</td> </tr> <tr> <td>-</td> <td>0</td> <td>0</td> <td>0</td> <td>0</td> <td>0</td> <td>1</td> <td>1</td> <td>Terminal Key</td> </tr> <tr> <td>P1</td> <td>-</td> <td>0</td> <td>0</td> <td>0</td> <td>0</td> <td>1</td> <td>0</td> <td>Card Key</td> </tr> <tr> <td></td> <td>-</td> <td>0</td> <td>0</td> <td>0</td> <td>0</td> <td>1</td> <td>0</td> <td>Bulk Encryption Key (Not diversified)</td> </tr> <tr> <td></td> <td>-</td> <td>0</td> <td>0</td> <td>0</td> <td>0</td> <td>1</td> <td>1</td> <td>Initial vector</td> </tr> <tr> <td></td> <td>0</td> <td>-</td> <td>-</td> <td>-</td> <td>-</td> <td>-</td> <td>-</td> <td>16-byte Key</td> </tr> <tr> <td></td> <td>1</td> <td>-</td> <td>-</td> <td>-</td> <td>-</td> <td>-</td> <td>-</td> <td>24-byte Key</td> </tr> </tbody> </table>	b7	b6	b5	b4	b3	b2	b1	b0	Description	-	0	0	0	0	0	0	1	Secret Code (Sc)	-	0	0	0	0	0	1	0	Account Key (K _{Acct})	-	0	0	0	0	0	1	1	Terminal Key	P1	-	0	0	0	0	1	0	Card Key		-	0	0	0	0	1	0	Bulk Encryption Key (Not diversified)		-	0	0	0	0	1	1	Initial vector		0	-	-	-	-	-	-	16-byte Key		1	-	-	-	-	-	-	24-byte Key
b7	b6	b5	b4	b3	b2	b1	b0	Description																																																																										
-	0	0	0	0	0	0	1	Secret Code (Sc)																																																																										
-	0	0	0	0	0	1	0	Account Key (K _{Acct})																																																																										
-	0	0	0	0	0	1	1	Terminal Key																																																																										
P1	-	0	0	0	0	1	0	Card Key																																																																										
	-	0	0	0	0	1	0	Bulk Encryption Key (Not diversified)																																																																										
	-	0	0	0	0	1	1	Initial vector																																																																										
	0	-	-	-	-	-	-	16-byte Key																																																																										
	1	-	-	-	-	-	-	24-byte Key																																																																										
P2	Index of Master Key: Bit7: 1 = local Key in current EF2; 0 = global KEY EF2 Bit6-Bit5: 00b - RFU Bit4-Bit0: Key Index																																																																																	
P3	If P1 = 1-4, P3 = 8/16, (if algo is AES, P3 = 8/16) If P1 = 5, P3 = 0 If P1 = 6, P3 = 8 (Algo of Master Key is DES/ 3DES/ 3KDES) P3 = 16 (Algo of Master Key is AES)																																																																																	
Data	If P1 = 1-4 Client card's Serial Number, (if algo is AES, Data is Client card's Serial Number or Client card's Serial Number append with "0000000000000000") If P1 = 5, No command data. If P1 = 6, DES/3DES/3KDES/AES CBC initial vector.																																																																																	

Specific Response Status Bytes

SW1 SW2	Description
69 86h	No DF selected
6A 86h	Wrong P1, P1 must be 1 to 6
67 00h	Wrong P3, P3 must be 8 (or 0)
62 83h	Current DF is blocked, or EF2 is blocked
69 82h	Security condition not satisfied
6A 88h	EF2 not found
6A 83h	Referenced Master Key in EF2 not found
69 81h	Invalid EF2 (FDB, MRL, etc., not consistent)



SW1 SW2	Description
6A 87h	Referenced KEY not capable of authentication
69 83h	Referenced Key is locked
90 00h	Target key generated, and ready in SAM memory

5.4.1.3. Encrypt

This command is used to encrypt data using DES or 3DES with either:

1. The session key created by the mutual authentication procedure with an ACOS3/6, DESFire®, DESFire® EV1/EV2/Light or MIFARE Plus card.
2. A diversified key (secret code).
3. A bulk encryption key.
4. Encrypt the diversified secret code with the session key.
5. Prepare ACOS3 secure messaging command given a non-SM command.

APDU	Description																																																																																																																																																
CLA	80h																																																																																																																																																
INS	74h																																																																																																																																																
	<table border="1"> <thead> <tr> <th>b7</th> <th>b6</th> <th>b5</th> <th>b4</th> <th>b3</th> <th>b2</th> <th>b1</th> <th>b0</th> <th>Description</th> </tr> </thead> <tbody> <tr> <td>-</td> <td>0</td> <td>0</td> <td>0</td> <td>0</td> <td>0</td> <td>0</td> <td>-</td> <td>ECB Mode</td> </tr> <tr> <td>-</td> <td>0</td> <td>0</td> <td>0</td> <td>0</td> <td>0</td> <td>1</td> <td>-</td> <td>CBC Mode</td> </tr> <tr> <td>-</td> <td>0</td> <td>0</td> <td>0</td> <td>0</td> <td>1</td> <td>0</td> <td>-</td> <td>Retail MAC Mode</td> </tr> <tr> <td>-</td> <td>0</td> <td>0</td> <td>0</td> <td>0</td> <td>1</td> <td>1</td> <td>-</td> <td>MAC Mode</td> </tr> <tr> <td>-</td> <td>0</td> <td>0</td> <td>0</td> <td>1</td> <td>0</td> <td>0</td> <td>-</td> <td>Prepare ACOS3 SM command.</td> </tr> <tr> <td>-</td> <td>1</td> <td>0</td> <td>0</td> <td>1</td> <td>0</td> <td>1</td> <td>-</td> <td>MIFARE DESFire Encryption</td> </tr> <tr> <td>-</td> <td>1</td> <td>0</td> <td>0</td> <td>1</td> <td>1</td> <td>0</td> <td>-</td> <td>MIFARE DESFire EV1/EV2/Light Encryption</td> </tr> <tr> <td>-</td> <td>0</td> <td>0</td> <td>0</td> <td>1</td> <td>1</td> <td>1</td> <td>-</td> <td>CMAC</td> </tr> <tr> <td>-</td> <td>0</td> <td>1</td> <td>0</td> <td>0</td> <td>0</td> <td>0</td> <td></td> <td>MIFARE Plus Command</td> </tr> <tr> <td>-</td> <td>0</td> <td>1</td> <td>0</td> <td>0</td> <td>0</td> <td>1</td> <td></td> <td>MIFARE Plus Response</td> </tr> <tr> <td>0</td> <td>-</td> <td>-</td> <td>-</td> <td>-</td> <td>-</td> <td>-</td> <td>0</td> <td>3DES</td> </tr> <tr> <td>0</td> <td>-</td> <td>-</td> <td>-</td> <td>-</td> <td>-</td> <td>-</td> <td>1</td> <td>DES</td> </tr> <tr> <td>1</td> <td>-</td> <td>-</td> <td>-</td> <td>-</td> <td>-</td> <td>-</td> <td>0</td> <td>3K DES</td> </tr> <tr> <td>1</td> <td>-</td> <td>-</td> <td>-</td> <td>-</td> <td>-</td> <td>-</td> <td>1</td> <td>AES</td> </tr> <tr> <td>-</td> <td>-</td> <td>-</td> <td>-</td> <td>-</td> <td>-</td> <td>-</td> <td>-</td> <td>All other values – RFU</td> </tr> </tbody> </table>	b7	b6	b5	b4	b3	b2	b1	b0	Description	-	0	0	0	0	0	0	-	ECB Mode	-	0	0	0	0	0	1	-	CBC Mode	-	0	0	0	0	1	0	-	Retail MAC Mode	-	0	0	0	0	1	1	-	MAC Mode	-	0	0	0	1	0	0	-	Prepare ACOS3 SM command.	-	1	0	0	1	0	1	-	MIFARE DESFire Encryption	-	1	0	0	1	1	0	-	MIFARE DESFire EV1/EV2/Light Encryption	-	0	0	0	1	1	1	-	CMAC	-	0	1	0	0	0	0		MIFARE Plus Command	-	0	1	0	0	0	1		MIFARE Plus Response	0	-	-	-	-	-	-	0	3DES	0	-	-	-	-	-	-	1	DES	1	-	-	-	-	-	-	0	3K DES	1	-	-	-	-	-	-	1	AES	-	-	-	-	-	-	-	-	All other values – RFU
b7	b6	b5	b4	b3	b2	b1	b0	Description																																																																																																																																									
-	0	0	0	0	0	0	-	ECB Mode																																																																																																																																									
-	0	0	0	0	0	1	-	CBC Mode																																																																																																																																									
-	0	0	0	0	1	0	-	Retail MAC Mode																																																																																																																																									
-	0	0	0	0	1	1	-	MAC Mode																																																																																																																																									
-	0	0	0	1	0	0	-	Prepare ACOS3 SM command.																																																																																																																																									
-	1	0	0	1	0	1	-	MIFARE DESFire Encryption																																																																																																																																									
-	1	0	0	1	1	0	-	MIFARE DESFire EV1/EV2/Light Encryption																																																																																																																																									
-	0	0	0	1	1	1	-	CMAC																																																																																																																																									
-	0	1	0	0	0	0		MIFARE Plus Command																																																																																																																																									
-	0	1	0	0	0	1		MIFARE Plus Response																																																																																																																																									
0	-	-	-	-	-	-	0	3DES																																																																																																																																									
0	-	-	-	-	-	-	1	DES																																																																																																																																									
1	-	-	-	-	-	-	0	3K DES																																																																																																																																									
1	-	-	-	-	-	-	1	AES																																																																																																																																									
-	-	-	-	-	-	-	-	All other values – RFU																																																																																																																																									
	<p>P2 is derived key in SAM set using Load Key function:</p> <p>1 – Encrypt Data with Session Key Ks 2 – Encrypt Data with Diversified Key Sc 3 – Encrypt Data with Bulk Encryption Key 0 – return ENC (Sc, Ks)</p> <p>If P1.b3 = 1 or b5=1, P2 must be 1 If P2 = 0h, P1 can be either 0 or 1</p>																																																																																																																																																



APDU	Description
P3	<p>P3 < 128</p> <p>If bit 3 of P1 not equal to 1 and bit 5 of P1 not equal to 1</p> <ul style="list-style-type: none"> - If P2 = 1-3, multiple of 8 (DES/3DES/3KDES) or 16 (AES) up to 128 bytes - If P2 = 0, 0
Data	<p>Plain text</p> <p>If P2 b6 = 1, The DATA format should be:</p> <ul style="list-style-type: none"> • Length of Plain text data • Length of Command and Header of DESFire Card • Command and Header of DESFire Card • Plain text <p>P1 = A1h, the encryption is for a MIFARE Plus command</p> <ul style="list-style-type: none"> • if MFP Command is <i>value</i> operations command, the DATA format should be Command code(1 BYTE)+BlockNum(2/4 BYTE)+Value(4 BYTE). • if MFP Command is <i>Proximity Check</i>, the DATA format should be Command code(1 BYTE)+ PPS1(1 BYTE). • if MFP Command is <i>Read</i>, the DATA format should be Command code(1 BYTE)+ BlockNum(2 BYTE) • if MFP Command is <i>Write</i>, the DATA format should be Command code(1 BYTE)+ BlockNum(2 BYTE) +plaintext <p>P1=A3h,</p> <ul style="list-style-type: none"> • The data return by ICC (don't include SC code and don't include RMAC if RMAC exist) <p>If authenticate with Authenticate EV2 First/ Authenticate EV2NonFirst command before, then P1 should be CDh or 8Fh.</p> <ul style="list-style-type: none"> • If P1=CDh, the encryption is for a DESFire EV2/Light command. The DATA format should be: Plain text data • If P1=8Fh, the CMAC is for a DESFire EV2/Light command or response. The DATA format should be: <ul style="list-style-type: none"> ➢ EV2 Command: The whole command without the CMAC data ➢ EV2 Response: The whole response from EV2 ➢ Light Command: The whole command without the CMAC data and the CLA/P1/P2/Lc/Le bytes. ➢ Light Response: The SW2 and Response data from Light. <p>If the EV2/Light card return the status code and plain text data only, then the data should be 00h, which should be sent to the SAM card.</p>

Specific Response Status Bytes

SW1 SW2	Description
69 86h	No DF selected
6A 86h	Invalid P1 or P2
67 00h	Incorrect P3
6A 83h	ACOS Target Key is not ready (use Diversify to generate the key)
61 XX	Encryption is done, use GET RESPONSE to get the result



5.4.1.4. Decrypt

This command is used to decrypt data using DES or 3DES or AES with either:

1. The session key created by the mutual authentication procedure with an ACOS3/6, MIFARE DESFire, MIFARE DESFire EV1/EV2/Light or MIFARE Plus card.
2. A diversified key (secret code).
3. A bulk encryption key.
4. Decrypt the diversified secret code with the session key.
5. Verify and Decrypt ACOS3 secure-messaging response.

Verify and Decrypt ACOS3 SM Response:

APDU	Description								
CLA	80h								
INS	76h								
	b7	b6	b5	b4	b3	b2	b1	b0	Description
	-	0	0	0	0	0	0	-	ECB Mode
	-	0	0	0	0	0	1	-	CBC Mode
	-	0	0	0	1	0	0	-	Verify and Decrypt ACOS3 SM Response
	-	1	0	0	1	0	1	-	MIFARE DESFire Decryption
P1	-	1	0	0	1	1	0	-	MIFARE DESFire EV1 Decryption
	-	0	1	0	0	1	0	-	MIFARE Plus Decryption
	0	-	-	-	-	-	-	0	3DES
	0	-	-	-	-	-	-	1	DES
	1	-	-	-	-	-	-	0	3K DES
	1	-	-	-	-	-	-	1	AES
	0	0	0	0	-	-	-	-	All other values - RFU
	P2 is derived key in SAM set using Load Key function:								
P2	1 – Decrypt Data with Session Key <i>Ks</i> 2 – Decrypt Data with Diversified Key <i>Sc</i> 3 – Decrypt Data with Bulk Encryption Key 0 – return DEC (<i>Sc</i> , <i>Ks</i>)								
	P3 < 128								
	If P1 = A5h, P3=16/32/48								
P3	If bit 3 of P1 not equal to 1 - If P2 = 1-3, multiple of 8 (DES/3DES/3KDES) or 16 (AES) up to 128 bytes - If P2 = 0, 0								



APDU	Description
	Ciphertext
	If P1 = A5h, The DATA is Encrypted text
	If P2 b6 = 1, The DATA format should be:
Data	<ul style="list-style-type: none"> Length of Plain text data, if unknown, use 00 Length of Command and Header of DESFire Card Command and Header of DESFire Card Encrypted text
	If authenticate with Authenticate EV2 First/ Authenticate EV2NonFirst command before, and the EV2/Light card return the encrypted and CMAC data, then P1 should be CDh. The DATA format should be:
	<ul style="list-style-type: none"> EV2 Response: The whole response from EV2 Light Response: The SW2 and Response data from Light.

Specific Response Status Bytes

SW1 SW2	Description
69 86h	No DF selected
6A 86h	Invalid P1 or P2
67 00h	Incorrect P3
6A 83h	ACOS Target Key is not ready (use Diversify to generate the key)
61 XX	Decryption is done, use GET RESPONSE to get the result

5.4.1.5. Prepare Authentication

This command is used to authenticate the SAM card (as the terminal) to the ACOS 3/6 card or MIFARE Ultralight C/MIFARE DESFire Card/MIFARE DESFire EV1/EV2/Light/MIFARE Plus card.

APDU	Description
CLA	80h
INS	78h
	00h – 3DES
	01h – DES
	02h – 3KDES (MIFARE DESFire EV1/ACOS3)
P1	03h – AES (MIFARE DESFire EV1/MIFARE Plus/ACOS3)
	80h – 3DES (MIFARE DESFire Authenticate only)
	81h – DES (MIFARE DESFire Authenticate only)
	Other – RFU
	0h – Verify ACOS3/6 Authenticate Return
	01h – MIFARE Ultralight C/DESFire Authenticate by (Diversified) Terminal Key
	05h – MIFARE Ultralight C/DESFire Authenticate by Bulk Encryption Key
P2	02h – MIFARE Plus Authenticate. First Authenticate of SL1 to SL3
	03h – MIFARE Plus Authenticate. Authentication in SL1 to SL2.
	04h – MIFARE Plus Authenticate. Following Authenticate of SL2 to SL3.



APDU	Description
	06h – MIFARE DESfire EV2/Light AuthenticateEV2First/AuthenticateEV2NonFirst/Mifare Plus EV1 secure messaging
P3	8 – (P1 = 00h, 01h, 02h, 80h, 81h) 16 – (P1 = 03h)
Data	Card Challenge Data

Specific Response Status Bytes

SW1 SW2	Description
69 86h	No DF selected
6A 86h	Invalid P1 or P2
67 00h	Incorrect P3, must be 08h
6A 83h	ACOS Key (KT or KC) is not ready (use Diversify to generate this key)
69 82h	Security condition not satisfied
61 10h	Command completed, issue GET RESPONSE to get the result

5.4.1.6. Verify Authentication

This command is used to verify the ACOS 3/6, MIFARE Ultralight C, MIFARE DESFire/MIFARE DESFire EV1 or MIFARE Plus card to the terminal. The Session Key Ks would also be generated internally.

APDU	Description
CLA	80h
INS	7Ah
P1	00h – 3DES (P2 = 0) 01h – DES (P2 = 0) 02h – 3KDES (P2 = 0 · ACOS3) 03h – AES (P2 = 0 · ACOS3) Other – RFU
P2	00h – Verify ACOS3/6 Authenticate Return 01h – Verify MIFARE Ultralight C®/ DESFire®/ DESFire® EV1 Authenticate Return 02h – Verify MIFARE Plus Authenticate return Or MIFARE DESFire EV2/Light AuthenticateEV2First/AuthenticateEV2NonFirst Return
P3	08h – (P2 = 0, P2 = 1 and Session Key is DES/3DES) 16h – (P2 = 1 and Session Key is 3KDES/AES) 16h – (P2=02, and MIFARE Plus return data ek(RndA')) 32h – (P2=02, and MIFARE Plus return data ek(TI+PICCap2+PCDcap2))
Data	ACOS 3/6: DES (Ks, RND _T) MIFARE DESFire/ DESFire EV1/EV2/Light return data: ek(RndA') MIFARE Plus return data ek(RndA') or ek(TI+PICCap2+PCDcap2)



Specific Response Status Bytes

SW1 SW2	Description
69 86h	No DF selected
6A 86h	Invalid P1 or P2
67 00h	Incorrect P3, must be 08h
6A 83h	ACOS-SAM Session Key or RND _T are not ready. Use PREPARE AUTHENTICATION to build these keys.
69 82h	Data is incorrect
90 00h	Data is correct, ACOS Mutual Authentication is successful

5.4.1.7. Verify ACOS Inquire Account

This command is used to verify the ACOS3/6 card's Inquire Account purse command. It would verify that the MAC checksum returned by ACOS3/6 are correct with the SAM's diversified key.

APDU	Description																																																																																	
CLA	80h																																																																																	
INS	7Ch																																																																																	
	<table border="1"> <thead> <tr> <th>b7</th> <th>b6</th> <th>b5</th> <th>b4</th> <th>b3</th> <th>b2</th> <th>b1</th> <th>b0</th> <th>Description</th> </tr> </thead> <tbody> <tr> <td>-</td> <td>0</td> <td>0</td> <td>0</td> <td>0</td> <td>-</td> <td>0</td> <td>-</td> <td>ACOS INQ_AUT is disabled</td> </tr> <tr> <td>-</td> <td>0</td> <td>0</td> <td>0</td> <td>0</td> <td>-</td> <td>1</td> <td>-</td> <td>ACOS INQ_AUT is enabled</td> </tr> <tr> <td>-</td> <td>0</td> <td>0</td> <td>0</td> <td>0</td> <td>0</td> <td>-</td> <td>-</td> <td>ACOS INQ_ACC_MAC is disabled</td> </tr> <tr> <td>P1</td> <td>-</td> <td>0</td> <td>0</td> <td>0</td> <td>0</td> <td>1</td> <td>-</td> <td>ACOS INQ_ACC_MAC is enabled</td> </tr> <tr> <td></td> <td>0</td> <td>-</td> <td>-</td> <td>-</td> <td>-</td> <td>-</td> <td>0</td> <td>3DES</td> </tr> <tr> <td></td> <td>0</td> <td>-</td> <td>-</td> <td>-</td> <td>-</td> <td>-</td> <td>1</td> <td>DES</td> </tr> <tr> <td></td> <td>1</td> <td>-</td> <td>-</td> <td>-</td> <td>-</td> <td>-</td> <td>0</td> <td>3K DES (ACOS3 only)</td> </tr> <tr> <td></td> <td>1</td> <td>-</td> <td>-</td> <td>-</td> <td>-</td> <td>-</td> <td>1</td> <td>AES (ACOS3 only)</td> </tr> </tbody> </table>	b7	b6	b5	b4	b3	b2	b1	b0	Description	-	0	0	0	0	-	0	-	ACOS INQ_AUT is disabled	-	0	0	0	0	-	1	-	ACOS INQ_AUT is enabled	-	0	0	0	0	0	-	-	ACOS INQ_ACC_MAC is disabled	P1	-	0	0	0	0	1	-	ACOS INQ_ACC_MAC is enabled		0	-	-	-	-	-	0	3DES		0	-	-	-	-	-	1	DES		1	-	-	-	-	-	0	3K DES (ACOS3 only)		1	-	-	-	-	-	1	AES (ACOS3 only)
b7	b6	b5	b4	b3	b2	b1	b0	Description																																																																										
-	0	0	0	0	-	0	-	ACOS INQ_AUT is disabled																																																																										
-	0	0	0	0	-	1	-	ACOS INQ_AUT is enabled																																																																										
-	0	0	0	0	0	-	-	ACOS INQ_ACC_MAC is disabled																																																																										
P1	-	0	0	0	0	1	-	ACOS INQ_ACC_MAC is enabled																																																																										
	0	-	-	-	-	-	0	3DES																																																																										
	0	-	-	-	-	-	1	DES																																																																										
	1	-	-	-	-	-	0	3K DES (ACOS3 only)																																																																										
	1	-	-	-	-	-	1	AES (ACOS3 only)																																																																										
P2	0h																																																																																	
P3	1Dh																																																																																	
Data	Data Block returned by INQUIRE ACCOUNT of client ACOS card.																																																																																	

Specific Response Status Bytes

SW1 SW2	Description
69 86h	No DF selected
6A 86h	Invalid P1 or P2
67 00h	Incorrect P3
6A 83h	ACOS Key K _s or K _{ACCT} are not ready; use DIVERSIFY command to generate K _{ACCT} ; if applicable, use "Prepare Authentication" to generate K _s .
6F 00h	Data Block's MAC is incorrect
90 00h	Data Block's MAC is correct



5.4.1.8. Prepare ACOS Account Transaction

To create an ACOS3/6 Credit/Debit command, the MAC must be computed for ACOS3/6 to verify.

APDU	Description																																				
CLA	80h																																				
INS	7Eh																																				
	<table border="1"> <thead> <tr> <th>b7</th> <th>b6</th> <th>b5</th> <th>b4</th> <th>b3</th> <th>b2</th> <th>b1</th> <th>b0</th> <th>Description</th> </tr> </thead> <tbody> <tr> <td>-</td> <td>0</td> <td>0</td> <td>0</td> <td>0</td> <td>0</td> <td>0</td> <td>-</td> <td>ACOS TRNS_AUT is disabled</td> </tr> <tr> <td>-</td> <td>0</td> <td>0</td> <td>0</td> <td>0</td> <td>0</td> <td>1</td> <td>-</td> <td>ACOS TRNS_AUT is enabled</td> </tr> </tbody> </table>	b7	b6	b5	b4	b3	b2	b1	b0	Description	-	0	0	0	0	0	0	-	ACOS TRNS_AUT is disabled	-	0	0	0	0	0	1	-	ACOS TRNS_AUT is enabled									
b7	b6	b5	b4	b3	b2	b1	b0	Description																													
-	0	0	0	0	0	0	-	ACOS TRNS_AUT is disabled																													
-	0	0	0	0	0	1	-	ACOS TRNS_AUT is enabled																													
P1	<table border="1"> <tbody> <tr> <td>0</td> <td>-</td> <td>-</td> <td>-</td> <td>-</td> <td>-</td> <td>-</td> <td>0</td> <td>3DES</td> </tr> <tr> <td>0</td> <td>-</td> <td>-</td> <td>-</td> <td>-</td> <td>-</td> <td>-</td> <td>1</td> <td>DES</td> </tr> <tr> <td>1</td> <td>-</td> <td>-</td> <td>-</td> <td>-</td> <td>-</td> <td>-</td> <td>0</td> <td>3K DES (ACOS3 only)</td> </tr> <tr> <td>1</td> <td>-</td> <td>-</td> <td>-</td> <td>-</td> <td>-</td> <td>-</td> <td>1</td> <td>AES (ACOS3 only)</td> </tr> </tbody> </table>	0	-	-	-	-	-	-	0	3DES	0	-	-	-	-	-	-	1	DES	1	-	-	-	-	-	-	0	3K DES (ACOS3 only)	1	-	-	-	-	-	-	1	AES (ACOS3 only)
0	-	-	-	-	-	-	0	3DES																													
0	-	-	-	-	-	-	1	DES																													
1	-	-	-	-	-	-	0	3K DES (ACOS3 only)																													
1	-	-	-	-	-	-	1	AES (ACOS3 only)																													
P2	E2h: Credit E6h: Debit																																				
P3	0Dh																																				
Data	Data Block																																				

Specific Response Status Bytes

SW1 SW2	Description
69 86h	No DF selected
6A 86h	Invalid P1 or P2
67 00h	Incorrect P3, must be 0Dh
6A 83h	ACOS Key K_S or K_{ACCT} are not ready; use DIVERSIFY command to generate K_{ACCT} ; if applicable, use "Prepare Authentication" to generate K_S .
61 0Bh	Command completed, issue GET RESPONSE to get the result



5.4.1.9. Verify Debit Certificate

For ACOS3/6, if the DEBIT command has P1 = 1, a debit certificate is returned. The debit certificate can be checked by comparing the ACOS3 response to the result of this command.

APDU	Description
CLA	80h
INS	70h
	b7 b6 b5 b4 b3 b2 b1 b0 Description
	- 0 0 0 0 0 0 - ACOS TRNS_AUT is disabled
	- 0 0 0 0 0 1 - ACOS TRNS_AUT is enabled
P1	0 - - - - - - 0 3DES
	0 - - - - - - 1 DES
	1 - - - - - - 0 3K DES (ACOS3 only)
	1 - - - - - - 1 AES (ACOS3 only)
P2	0h
P3	14h
Data	Data Block

Specific Response Status Bytes

SW1 SW2	Description
69 86h	No DF selected
6A 86h	Invalid P1 or P2
67 00h	Incorrect P3, must be 14h
6A 83h	ACOS Key K _s or K _{ACCT} are not ready; use DIVERSIFY command to generate K _{ACCT} ; if applicable, use PREPARE AUTHENTICATION to generate K _s .
69 82h	Security condition not satisfied
6F 00h	DEBIT CERTIFICATE is invalid
90 00h	Success, DEBIT CERTIFICATE is valid

5.4.1.10. Get Key

This command allows secure key injection from the current SAM's Key File (SFI=02h) into another ACOS6/ACOS6-SAM with or without key diversification. Using this ensures that the keys to be injected are protected by encryption and message authentication codes.

The Get Key command also allows secure key injection from the current SAM's Key File (SFI=02h) into ACOS7/10, MIFARE DESFire, MIFARE DESFire EV1/EV2/Light or MIFARE Plus card with key diversification. Using this ensures that the key to be injected is protected by encryption and message authentication codes.

If bit 7 of the Special Function Flag (Key Injection Only Flag) of the **Card Header Block** (Section 4.2 of ACOS6-SAM Reference Manual) has been set and the key file has been activated, Get Key must be used for loading or changing keys in the card. Setting this bit will disable Read Record command for the key file under any circumstances after activation.



Before this command is to be executed, a session key is already established with the target card with the mutual authentication procedure of **Mutual Authentication** (Section 6.3 of ACOS6-SAM Reference Manual) or the MIFARE Plus/MIFARE DESFire mutual authentication procedure.

Note: The GET KEY command can only get the Key data.

APDU	Description																												
CLA	80h																												
INS	CAh																												
	Get Key for ACOS card Set Key																												
	00h Response data is Key in MSAM																												
	01h Response data is 16-byte Diversify Key																												
	02h Response data is 24-byte Diversify Key																												
	03h Response data is the Change Key command of MIFARE Plus Card																												
	Get Key for DESFire card Change Key, Response data for DESFire/DESFire EV1 Change Key																												
	<table border="1"> <thead> <tr> <th></th> <th>Card Type</th> <th>Authenticate Key No. And Changing Key No.*</th> <th>Key Length</th> </tr> </thead> <tbody> <tr> <td>P1</td> <td>80h MIFARE DESFire</td> <td>Are DIFFERENT in MIFARE DESFire card</td> <td>16 bytes</td> </tr> <tr> <td></td> <td>81h MIFARE DESFire EV1</td> <td>Are DIFFERENT in MIFARE DESFire EV1 card</td> <td>16 bytes</td> </tr> <tr> <td></td> <td>82h MIFARE DESFire EV1</td> <td>Are DIFFERENT in MIFARE DESFire EV1 card</td> <td>24 bytes</td> </tr> <tr> <td></td> <td>88h MIFARE DESFire</td> <td>Are the SAME in MIFARE DESFire card</td> <td>16 bytes</td> </tr> <tr> <td></td> <td>89h MIFARE DESFire EV1</td> <td>Are the SAME in MIFARE DESFire EV1 card</td> <td>16 bytes</td> </tr> <tr> <td></td> <td>8Ah MIFARE DESFire EV1</td> <td>Are the SAME in MIFARE DESFire EV1 card</td> <td>24 bytes</td> </tr> </tbody> </table>		Card Type	Authenticate Key No. And Changing Key No.*	Key Length	P1	80h MIFARE DESFire	Are DIFFERENT in MIFARE DESFire card	16 bytes		81h MIFARE DESFire EV1	Are DIFFERENT in MIFARE DESFire EV1 card	16 bytes		82h MIFARE DESFire EV1	Are DIFFERENT in MIFARE DESFire EV1 card	24 bytes		88h MIFARE DESFire	Are the SAME in MIFARE DESFire card	16 bytes		89h MIFARE DESFire EV1	Are the SAME in MIFARE DESFire EV1 card	16 bytes		8Ah MIFARE DESFire EV1	Are the SAME in MIFARE DESFire EV1 card	24 bytes
	Card Type	Authenticate Key No. And Changing Key No.*	Key Length																										
P1	80h MIFARE DESFire	Are DIFFERENT in MIFARE DESFire card	16 bytes																										
	81h MIFARE DESFire EV1	Are DIFFERENT in MIFARE DESFire EV1 card	16 bytes																										
	82h MIFARE DESFire EV1	Are DIFFERENT in MIFARE DESFire EV1 card	24 bytes																										
	88h MIFARE DESFire	Are the SAME in MIFARE DESFire card	16 bytes																										
	89h MIFARE DESFire EV1	Are the SAME in MIFARE DESFire EV1 card	16 bytes																										
	8Ah MIFARE DESFire EV1	Are the SAME in MIFARE DESFire EV1 card	24 bytes																										
P2	Key ID in SAM (New key for change)																												
	If P1 = 00h, P3 is 08h																												
P3	If P1 = 01/02h, P3 is 10h																												
	If P1 = 03h, P3 is 0Bh																												
	If P1 = 80/81/82/88/89/8Ah: P3 is 0Bh or 0Dh																												



APDU	Description
	If P1 = 00h, command data is RND _{Target}
	If P1 = 01/02h, command data is RND _{Target} + serial (or batch) number of target card
	If P1 = 03h
	- Serial Number for target card (8 Byte)
	- Write Command (A0 or A1) (1 Byte)
	- BNr (2 Byte)
Data	If P1 = 80/81/82/88/89/8Ah:
	- Serial Number for target card (8 Byte)
	- Original Key ID (Key in SAM card stored the Original key, 00 = Default Key of DESFire - Card)
	- Key No. (DESFire Card Key No.)
	- Key Version (DESFire Card Key Version, If not used, value = 00)
	- Command:C6 (Optional)
	- KeySetNo (Optional)

* This column points out if the listed cards have a distinct Change Key and Authenticate Key, or if they use the same value for both keys.

Specific Response Status Bytes

SW1 SW2	Description
69 85h	SAM Session Key not ready
62 83h	Current DF is blocked, or Target EF is blocked
69 86h	No DF selected
69 81h	Wrong file type of Key file, it should be Internal Linear Variable File
69 82h	Target file's header block has wrong checksum, or security condition not satisfied
6A 86h	Invalid P1 or P2
67 00h	Incorrect P3
6A 83h	Target Key is not ready or Key Length less than 16
61 1Ch	Success, use GET RESPONSE to get the result



5.5. Contactless Smart Card Protocol

5.5.1. ATR Generation

If the reader detects a PICC, an ATR will be sent to the PCSC driver for identifying the PICC.

5.5.1.1. ATR Format for ISO14443 Part 3 PICCs

Byte	Value	Designation	Description
0	3Bh	Initial Header	
1	8Nh	T0	Higher nibble 8 means: no TA1, TB1, TC1 only TD1 is following. Lower nibble N is the number of historical bytes (HistByte 0 to HistByte N-1)
2	80h	TD1	Higher nibble 8 means: no TA2, TB2, TC2 only TD2 is following. Lower nibble 0 means T = 0
3	01h	TD2	Higher nibble 0 means no TA3, TB3, TC3, TD3 following. Lower nibble 1 means T = 1
4 ~ 3+N	80h	T1	Category indicator byte, 80 means A status indicator may be present in an optional COMPACT-TLV data object
	4Fh	Tk	Application identifier Presence Indicator
	0Ch		Length
	RID		Registered Application Provider Identifier (RID) # A0 00 00 03 06
	SS		Byte for standard
	C0 .. C1h		Bytes for card name
	00 00 00 00h	RFU	RFU # 00 00 00 00
4+N	UU	TCK	Exclusive-oring of all the bytes T0 to Tk

Example:

ATR for MIFARE Classic 1K = {3B 8F 80 01 80 4F 0C A0 00 00 03 06 03 00 01 00 00 00 00 6Ah}

Where:

Length (YY) = 0Ch
RID = {A0 00 00 03 06h} (PC/SC Workgroup)
Standard (SS) = 03h (ISO 14443A, Part 3)
Card Name (C0 .. C1) = {00 01h} (MIFARE Classic 1K)
Standard (SS) = 03h: ISO 14443A, Part 3
= 11h: FeliCa

Card Name (C0 .. C1):

00 01: MIFARE Classic 1K	00 38: MIFARE Plus® SL2 2K
00 02: MIFARE Classic 4K	00 39: MIFARE Plus® SL2 4K
00 03: MIFARE Ultralight®	00 30: Topaz and Jewel
00 26: MIFARE Mini®	00 3B: FeliCa
00 3A: MIFARE Ultralight® C	FF 28: JCOP 30
00 36: MIFARE Plus® SL1 2K	FF [SAK]: undefined tags
00 37: MIFARE Plus® SL1 4K	

5.5.1.2. ATR Format for ISO14443 Part 4 PICCs

Byte	Value	Designation	Description						
0	3Bh	Initial Header							
1	8Nh	T0	Higher nibble 8 means: no TA1, TB1, TC1 only TD1 is following. Lower nibble N is the number of historical bytes (HistByte 0 to HistByte N-1)						
2	80h	TD1	Higher nibble 8 means: no TA2, TB2, TC2 only TD2 is following. Lower nibble 0 means T = 0						
3	01h	TD2	Higher nibble 0 means no TA3, TB3, TC3, TD3 following. Lower nibble 1 means T = 1						
4 ~ 3+N	XX	T1	Historical Bytes: ISO 14443-A: The historical bytes from ATS response. Refer to the ISO 14443-4 specification. ISO 14443-B: <table border="1" style="width: 100%; border-collapse: collapse;"> <thead> <tr> <th>Byte 1~4</th> <th>Byte 5~7</th> <th>Byte 8</th> </tr> </thead> <tbody> <tr> <td>Application Data from ATQB</td> <td>Protocol Info Byte from ATQB</td> <td>Higher nibble=MBLI from ATTRIB command Lower nibble (RFU)=0</td> </tr> </tbody> </table>	Byte 1~4	Byte 5~7	Byte 8	Application Data from ATQB	Protocol Info Byte from ATQB	Higher nibble=MBLI from ATTRIB command Lower nibble (RFU)=0
	Byte 1~4	Byte 5~7		Byte 8					
	Application Data from ATQB	Protocol Info Byte from ATQB		Higher nibble=MBLI from ATTRIB command Lower nibble (RFU)=0					
XX	Tk								
4+N	UU	TCK	Exclusive-oring of all the bytes T0 to Tk						

Example 1:

ATR for MIFARE® DESFire® = {3B 81 80 01 80 80h} // 6 bytes of ATR

Note: Use the APDU “FF CA 01 00 00h” to distinguish the ISO 14443A-4 and ISO 14443B-4 PICCs, and retrieve the full ATS if available. ISO 14443A-3 or ISO 14443B-3/4 PICCs do have ATS returned.

APDU Command = FF CA 01 00 00h
 APDU Response = 06 75 77 81 02 80 90 00h
 ATS = {06 75 77 81 02 80h}

Example 2:

ATR for EZ-Link = {3B 88 80 01 1C 2D 94 11 F7 71 85 00 BEh}
 Application Data of ATQB = 1C 2D 94 11h
 Protocol Information of ATQB = F7 71 85h
 MBLI of ATTRIB = 00h

5.5.2. APDU, Pseudo APDU and Card Native Command

CCID Host could send Card Native Command or APDU to the Reader by using CCID Message PC_to_RDR_XfrBlock (corresponding to SCardTransmit() in PCSC API). For PICC, if the card support ISO14443 part 4 protocol or Innovatron protocol, the Reader will pack the Command/APDU into the protocol frame and send to the card directly without any interpretation of the Command/APDU. If the card do not support neither protocol, a message “6A 81” will return to CCID Host.

Note: Due to Microsoft Window Smart Card Plug and Play, Microsoft Window may send some APDU to a card at the time of card present. This action will make a DESFire card entering ISO APDU mode such that the card become fail to receive a native command until a card reset. Usually Microsoft Window will reset the card (by PC_to_RDR_IccPowerOff) after 10s of inactive.

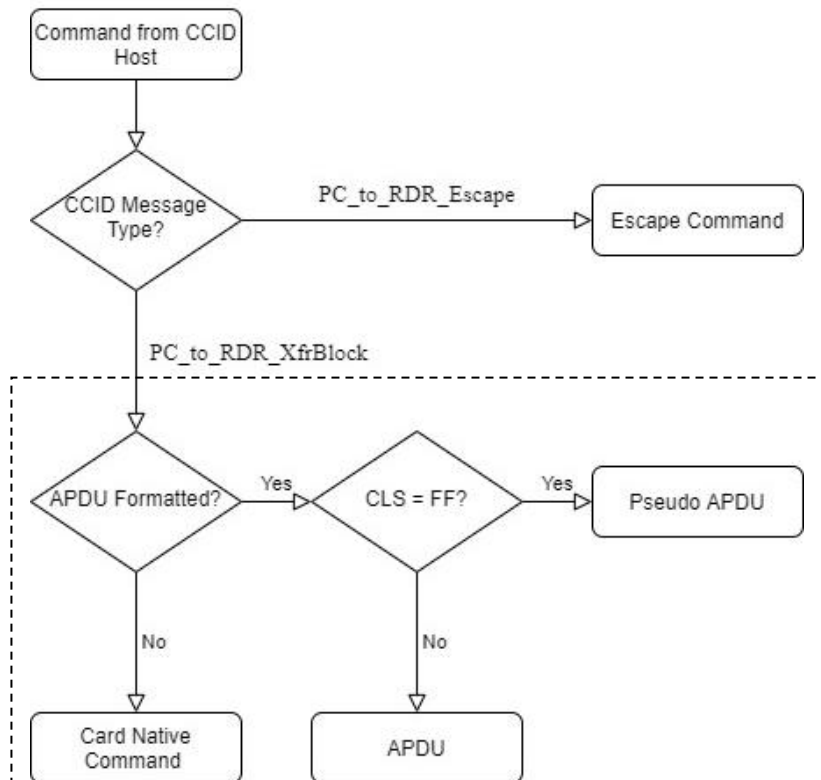

5.5.3. PCSC Pseudo APDU (with Proprietary Extension) for PICC

The following Pseudo APDUs are provided to access a contactless card indirectly. CCID Host could send these APDUs to Reader by using CCID Message PC_to_RDR_XfrBlock (corresponding to SCardTransmit() in PCSC API). After receiving of a Pseudo APDU, it will be interpreted to generate low level card command(s) and then send to card. After the card handling those low level command(s), Reader collect the response(s) from the card and create a response to send back to CCID Host.



5.5.3.1. Get Data [FF CA ...]

This command is used to read out the data obtained during activation process, such as serial number, protocol parameter etc.

Command

Command	Class	INS	P1	P2	Le
Get Data	FFh	CAh	See below		00h (Full Length)

Command Parameter

P1	P2	Meaning
00h	00h	Get the UID/PUPI/SN of the Card
01h	00h	Get the ATS for Type A Part 4
02h	00h	Get the following Card Type related data in transmission order: Type A: 2 bytes ATQA/ATVA + 4/7/10 Bytes UID + 1 bytes Last SAK. Type B: 12 bytes ATQB
80h	00h	Get the following Card Type related data in transmission order: Type A: 2 bytes ATQA/ATVA + 4/7/10 Bytes UID + 1/2/3 bytes SAK. Type B: 12 bytes ATQB FeliCa: 17 byte ATQ (+ 6 byte ATTR if activated) SRI: 8 byte UID + 1 byte Chip ID. ISO15693: 1 byte DSFID + 8 byte UID CTS: 4 byte SN + 2 byte ATQT Innovatron: 4 byte SN + 1 byte tag address.

Response

Response	Data Out		
Result	Data	SW1	SW2

Response Code

Results	SW1 SW2	Meaning
Success	90 00h	The operation was completed successfully.
Error	6X XXh	Fail.

Examples:

To get the serial number of the “connected PICC”:

```
UINT8 GET_UID[5] = {FF, CA, 00, 00, 00};
```



To get the ATS of the “connected ISO 14443 A PICC”:

UINT8 GET_ATS[5] = {FF, CA, 01, 00, 00};

5.5.3.2. Load Key [FF 82 ...]

This command is used to set the Key Data to the internal key buffer specified by Key Buffer Number. The key buffer is volatile and its content would be used during authentication. This command will not generate card data transfer.

Command

Command	Class	INS	P1	P2	Lc	Data In
Load Authentication Keys	FFh	82h	00h	Key Buffer Number (0 to 1)	Key Length	Key Data

Key Length/Data

Card Type	Key Length (Lc)	Key Data (in Transmission/Storing Order)
MIFARE Standard MIFARE Plus SL1	06h	6 Bytes Crypto1 Key A/B.
MIFARE Plus SL1 MIFARE Plus SL2	16h	6 Bytes Crypto1 Key A/B + 16 Bytes AES Key.
MIFARE Plus SL2	06h	6 Bytes Encrypted Crypto1 Key A/B.
MIFARE UltraLightC MIFARE DESFire	10h	16 Bytes 2K3DES Key.

Response Code

Results	SW1 SW2	Meaning
Success	90 00h	The operation was completed successfully.
Error	6X XXh	Fail.

Example:

// Load a key {FF FF FF FF FF FFh} into the volatile memory location 00h.

APDU = {FF 82 00 00 06 FF FF FF FF FF FFh}



5.5.3.3. Authenticate [FF 86 00 00 05 ...]

This command is used to performing an authentication to the card to grand access of the protected blocks/pages. Before sending this command, User should use Load Key command to set the correct key data to the buffer specified by **Key Buffer Number**.

Command

Command	Class	INS	P1	P2	Lc	Data In
Authenticate	FFh	86h	00h	00h	05h	See Below

Command Data

Byte 0	Byte 1	Byte 2	Byte 3	Byte 4
01h	00h (RFU)	Address	Key Type	Key Buffer Number

Address and Key Type

Card Type	Address	Key Type
MIFARE Standard MIFARE Plus SL1 MIFARE Plus SL2	00h~FFh: Block 0~255	60h: Crypto1 Key A 61h: Crypto1 Key B
MIFARE UltraLightC	00h (RFU)	80h: 2K3DES
MIFARE DESFire	00h~0Eh: DESFire Key Number 0~14	0Ah: 2K3DES

Response Code

Results	SW1 SW2	Meaning
Success	90 00h	The operation was completed successfully.
Error	6X XXh	Fail.

Sectors (Total 16 sectors. Each sector consists of 4 consecutive blocks)	Data Blocks (3 blocks, 16 bytes per block)	Trailer Block (1 block, 16 bytes)	} 1 KB
Sector 0	00h – 02h	03h	
Sector 1	04h – 06h	07h	
..	
..	
Sector 14	38h – 0Ah	3Bh	
Sector 15	3Ch – 3Eh	3Fh	

Table 12: MIFARE Classic 1K Memory Map



Sectors (Total 32 sectors. Each sector consists of 4 consecutive blocks)	Data Blocks (3 blocks, 16 bytes per block)	Trailer Block (1 block, 16 bytes)
Sector 0	00h ~ 02h	03h
Sector 1	04h ~ 06h	07h
..		
..		
Sector 30	78h ~ 7Ah	7Bh
Sector 31	7Ch ~ 7Eh	7Fh

} 1 KB

Sectors (Total 8 sectors. Each sector consists of 16 consecutive blocks)	Data Blocks (15 blocks, 16 bytes per block)	Trailer Block (1 block, 16 bytes)
Sector 32	80h ~ 8Eh	8Fh
Sector 33	90h ~ 9Eh	9Fh
..		
..		
Sector 38	E0h ~ EEh	EFh
Sector 39	F0h ~ FEh	FFh

} 2 KB

Table 13: MIFARE Classic 4K Memory Map



Byte Number	0	1	2	3	Page
Serial Number	SN0	SN1	SN2	BCC0	0
Serial Number	SN3	SN4	SN5	SN6	1
Internal/Lock	BCC1	Internal	Lock0	Lock1	2
OTP	OPT0	OPT1	OTP2	OTP3	3
Data read/write	Data0	Data1	Data2	Data3	4
Data read/write	Data4	Data5	Data6	Data7	5
Data read/write	Data8	Data9	Data10	Data11	6
Data read/write	Data12	Data13	Data14	Data15	7
Data read/write	Data16	Data17	Data18	Data19	8
Data read/write	Data20	Data21	Data22	Data23	9
Data read/write	Data24	Data25	Data26	Data27	10
Data read/write	Data28	Data29	Data30	Data31	11
Data read/write	Data32	Data33	Data34	Data35	12
Data read/write	Data36	Data37	Data38	Data39	13
Data read/write	Data40	Data41	Data42	Data43	14
Data read/write	Data44	Data45	Data46	Data47	15

} 512 bits
or
64 bytes

Table 14: MIFARE Ultralight Memory Map

Examples:

// To authenticate the Block 04h with a {TYPE A, key number 00h}. PC/SC V2.01, Obsolete
APDU = {FF 88 00 04 60 00h};

// To authenticate the Block 04h with a {TYPE A, key number 00h}. PC/SC V2.07
APDU = {FF 86 00 00 05 01 00 04 60 00h}

Note: MIFARE Ultralight does not need to do any authentication. The memory is free to access.



5.5.3.4. Read Binary Blocks [FF B0 ...]

This command is used to read specified number of byte of data from PICC starting from the specified block/page address. Depend on card type, user may need to perform authentication to get the access right of the required block(s)/page(s) before sending this command.

Command:

Command	Class	INS	P1	P2	Le
Read Binary Blocks	FFh	B0h	Mode and Address		Number of Bytes to Read

P1/P2 (Mode and Address)

Card Type	P1[7:4] Mode	P1[3:0] + P2[7:0] Starting Address (MSB First)
MIFARE Standard MIFARE Plus SL1 MIFARE Plus SL2	0h: Skip Trailers 8h: With Trailers	000h~0FFh: Block 0~255
MIFARE Ultralight MIFARE UltraLightC	0h (Reserved)	000h~02Fh: Page 0~47
SRIX4K/SRT512	0h (Reserved)	000h~07Fh: Block 0~127 0FFh: System Area
PicoPass	0h (Reserved)	000h~0FFh: Block 0~255
ISO15693	0h (Reserved)	000h~7FFh: Block 0~2047
Topaz/NFC Type-1 Tag	0h (Reserved)	000h~7FFh: Byte Address
CTS	0h (Reserved)	000h~01Fh: Block 0~31

Le (Number of Bytes to Read)

Type	Byte 0	Byte 1	Byte 2
Short	00h: Read 256 bytes 01h~FFh: Read 1~255 bytes	--	
Extended	00h	0000h: Read 65536 bytes 0001h~FFFFh: Read 1~65535 bytes	

Response Code

Results	SW1 SW2	Meaning
Success	90 00h	The operation was completed successfully.
Error	6X XXh	Fail.



Examples:

// Read 16 bytes from the binary block 04h (MIFARE Classic 1K or 4K)

APDU = FF B0 00 04 10h

// Read 240 bytes starting from the binary block 80h (MIFARE Classic 4K)

// Block 80h to Block 8Eh (15 blocks)

APDU = FF B0 00 80 F0h

5.5.3.5. Update Binary Blocks [FF D6 ...]

This command is used to write specified number (must be multiple of block/page size) of bytes to PICC starting from the specified block/page address. Depend on card type, user may need to perform authentication to get the access right of the required block(s)/page(s) before sending this command.

User should take a great care for writing to block/page that may change the security setting of the card (e.g. sector trailers of MIFARE card) as this may lock the card if incorrect data is written or operation is failed. As a result, to minimize the risk of card locking, it is not recommended to write to multiple block/page in a single APDU command if security block/page is involved.

Command

Command	Class	INS	P1	P2	Lc	Data In
Update Binary Blocks	FFh	D6h	Mode and Address		Number of Bytes to Write	Data Bytes

P1/P2 (Mode and Address) and Write Size alignment (Block/Page Size)

Card Type	P1[7:4] Mode	P1[3:0] + P2[7:0] Starting Address (MSB First)	Blk/Page Size (Bytes)
MIFARE Standard MIFARE Plus SL1 MIFARE Plus SL2	0h: Skip Trailers 8h: With Trailers	000h~0FFh: Block 0~255	16
MIFARE Ultralight MIFARE UltraLightC	0h (Reserved)	000h~02Fh: Page 0~47	4
SRIX4K/SRT512	0h (Reserved)	SRIX4K/SRT512	4
PicoPass	0h (Reserved)	PicoPass	8
ISO15693	0h (Reserved)	000h~7FFh: Block 0~2047	ISO15693
Topaz/NFC Type-1 Tag	0h: with Erase 8h: without Erase	000h~7FFh: Byte Address	1(Addr 78h) or 8(Else)
CTS	0h (Reserved)	000h~01Fh: Block 0~31	CTS



Lc (Number of Bytes to Write)

Type	Byte 0	Byte 1	Byte 2
Short	01h~FFh: Write 1~255 bytes	--	
Extended	00h	0001h~FFFFh: Write 1~65535 bytes	

Response Code

Results	SW1 SW2	Meaning
Success	90 00h	The operation was completed successfully.
Error	6X XXh	Fail.

Examples:

// Update the binary block 04h of MIFARE Classic 1K/4K with Data {00 01 .. 0Fh}

APDU = {FF D6 00 04 10 00 01 02 03 04 05 06 07 08 09 0A 0B 0C 0D 0E 0Fh}

// Update the binary block 04h of MIFARE Ultralight with Data {00 01 02 03h}

APDU = {FF D6 00 04 04 00 01 02 03h}

5.5.4. Pass Through Command

5.5.4.1. Accessing ISO14443-3 Tags

This section demonstrates how to use the pass-through command format to send commands compliant with ISO14443-3, the firmware requirement is illustrated as follow:

- ACR1555U FW 1.3.1

Command

Command	Class	INS	P1	P2	Lc	Data In
ISO14443-3 Command	FFh	00h	00h	00h	Data Length	Data

Response

Response	Data Out
Result	SW1 SW2

Response Code

Results	SW1 SW2	Meaning
Success	90 00h	The operation was completed successfully.
Error	6X XXh	Fail.



5.5.4.1.1. Transfer ISO14443-3 Native Command to Pass Though Command

This section explains how to convert ISO14443 native commands into the pass-through format.

Example:

- Mifare Ultralight AES Get Version
60
- Pass Though Format
FF 00 00 00 01 60

5.5.4.2. Accessing ISO15693 Tags

This section shows use pass though command format to send the commands for ISO15693.

Command

Command	Class	INS	P1	P2	Lc	Data In	Le
ISO15693 Command	FFh	FBh	00h	Flags	Data Length+1	Command Code Data	--/00h

Where:

- Flags: 00h(Default): set flags to 22h but data does not need to include the UID
Others: use the value as flags value

Response

Response	Data Out		
Result	Data	SW1	SW2

Response Code

Results	SW1 SW2	Meaning
Success	90 00h	The operation was completed successfully.
Error	6X XXh	Fail.

5.5.4.2.1. Transfer ISO15693 Command to Pass Though Command

This section introduce how to transfer ISO15693 command into pass though format. Notice that the pass though command only support those commands which run in 26kbps speed. For those commands which support 53kbps please refer to **APDU Commands for PCSC 2.0 Part 3 (Version 2.02 or above)**.

Example 1:

Stay Quiet (Mandatory Command)

22 02 XX XX XX XX XX XX XX XX

Where:

- 22 Flags
- 02 Stay quiet command code



XX XX XX XX XX XX XX XX 8 bytes UID

Pass Through Format

FF FB 00 22 09 02 XX XX XX XX XX XX XX XX

Or

FF FB 00 00 01 02

Example 2:

Read Multiple Blocks with not addressed (Optional Command)

02 23 00 01

Where:

- 02 Flags
- 23 Read multiple blocks command code
- 00 First block number
- 01 Read 2 blocks

Pass Through Format

FF FB 00 02 03 23 00 01

Example 3:

Get Random Number in Selected state (Custom Command for NXP SLIX2)

12 B2 04

Where:

- 12 Flags
- B2 Get random number command code
- 04 NXP manufacturer code

Pass Through Format

FF FB 00 12 02 B2 04



5.5.4.2.2. Supported Commands list

The following table lists all commands specified in ISO15693-3. Commands marked as N/A indicate that testing has not yet been performed. For inquiries regarding these commands, please contact info@acs.com.hk. Please note that ISO15693 cards may not support all optional commands. Refer to the respective card's datasheet to confirm command support.

Command Code	Type	Function	Support
01h	Mandatory	Inventory	Yes
02h	Mandatory	Stay Quiet	Yes
20h	Optional	Read Single Block	Yes
21h	Optional	Write Single Block	Yes
22h	Optional	Lock Block	Yes
23h	Optional	Read Multiple Blocks	Yes
24h	Optional	Write Multiple Blocks	Yes
25h	Optional	Select	Yes
26h	Optional	Reset to Ready	Yes
27h	Optional	Write AFI	Yes
28h	Optional	Lock AFI	Yes
29h	Optional	Write DSFID	Yes
2Ah	Optional	Lock DSFID	Yes
2Bh	Optional	Get System Information	Yes
2Ch	Optional	Get Multiple Block Security Status	Yes
2Dh	Optional	Fast Read Multiple Blocks	No
30h	Optional	Extended Read Single Block	Yes
31h	Optional	Extended Write Single Block	Yes
32h	Optional	Extended Lock Block	Yes
33h	Optional	Extended Read Multiple Blocks	Yes
34h	Optional	Extended Write Multiple Blocks	Yes
35h	Optional	Authenticate	Yes
36h	Optional	KeyUpdate	N/A
37h	Optional	AuthComm Crypto Format Indicator	N/A
38h	Optional	SecureComm Crypto Format Indicator	N/A
39h	Optional	Challenge	No
3Ah	Optional	ReadBuffer	Yes
3Bh	Optional	Extended Get System Information	Yes
3Ch	Optional	Extended Get Multiple Block Security Status	Yes
3Dh	Optional	Fast Extended Read Multiple Blocks	No
A0-DFh	Custom	IC Mfg Dependent	N/A
E0-FFh	Proprietary	IC Mfg Dependent	N/A



5.5.4.3. Accessing FeliCa tags

For FeliCa access, the command is different from the one used in PCSC-compliant and MIFARE tags. The command follows the FeliCa specification with an added header.

FeliCa Command Format

Command	Class	INS	P1	P2	Lc	Data In
FeliCa Command	FFh	00h	00h	00h	Length of the Data In	FeliCa Command (start with Length Byte)

FeliCa Response Format (Data + 2 bytes)

Response	Data Out
Result	Response Data

Read Memory Block Example:

1. Connect the FeliCa.

The ATR = 3B 8F 80 01 80 4F 0C A0 00 00 03 06 **11 00 3B** 00 00 00 00 42h

In which, **11 00 3Bh** = FeliCa

2. Read FeliCa IDM.

CMD = FF CA 00 00 00h

RES = [IDM (8bytes)] 90 00h

e.g., FeliCa IDM = 01 01 06 01 CB 09 57 03h

3. FeliCa command access.

Example: "Read" Memory Block.

CMD = FF 00 00 00 10 10 06 **01 01 06 01 CB 09 57 03** 01 09 01 01 80 00h

where:

Felica Command = 10 06 **01 01 06 01 CB 09 57 03** 01 09 01 01 80 00h

IDM = **01 01 06 01 CB 09 57 03h**

RES = Memory Block Data

5.5.5. APDU Commands for PCSC 2.0 Part 3 (Version 2.02 or above)

PCSC2.0 Part 3 commands are used to transparently pass data from an application to a contactless tag, return the received data transparently to the application and protocol, and switch the protocol simultaneously.

5.5.5.1. PCSC 2.0 Part 3 Flow

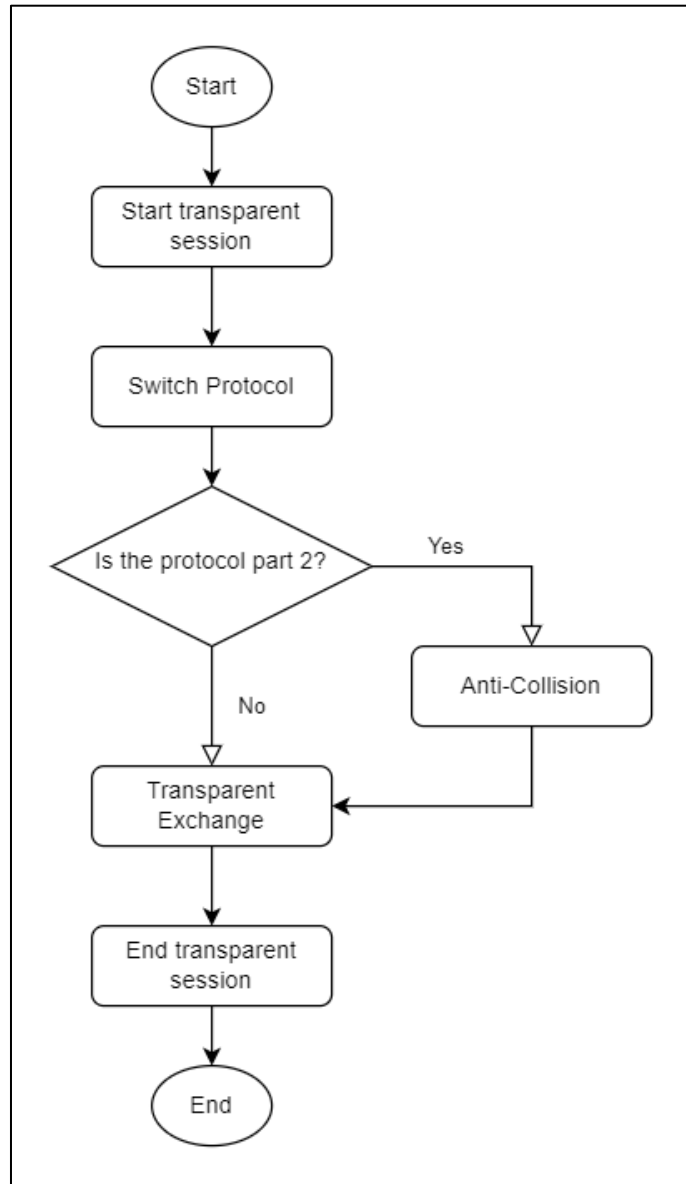

Figure 9: Transparent Session Flow



5.5.5.2. Command and Response APDU Format

Command Format

CLA	INS	P1	P2	Lc	Data In
FFh	C2h	00h	Function	DataLen	Data[DataLen]

Where Functions (1 byte):

- 00h = Manage Session
- 01h = Transparent Exchange
- 02h = Switch Protocol
- Other = RFU

Response Format

Data Out	SW1	SW2
Data Field BER-TLV encoded		

Every command returns SW1 and SW2 together with the response data field (if available). The SW1 SW2 is based on ISO 7816. SW1 SW2 from the C0 data object below should also be used.

C0 data element Format

Tag	Length (1 byte)	SW2
C0h	03h	Error Status

Error Status Description

Error Status	Description
XX SW1 SW2	XX = number of the bad data object in the APDU 00 = general error of APDU 01 = error in the 1 st data object 02 = error in the 2 nd data object
00 90 00h	No error occurred
XX 62 82h	Data object XX warning, requested information not available
XX 63 00h	No information
XX 63 01h	Execution stopped due to failure in other data object
XX 6A 81h	Data object XX not supported
XX 67 00h	Data object XX with unexpected length
XX 6A 80h	Data object XX with unexpected value
XX 64 00h	Data Object XX execution error (no response from IFD)
XX 64 01h	Data Object XX execution error (no response from ICC)
XX 6F 00h	Data object XX failed, no precise diagnosis

The first value byte indicates the number of the erroneous data object XX, while the last two bytes indicate the explanation of the error. SW1 SW2 values based on ISO 7816 are allowed.

If there are more than one data objects in the C-APDU field and one data object failed, IFD can process the following data objects if they do not depend on the failed data objects.



5.5.5.3. Manage Session [FF C2 00 00 ...]

This command allows user to start a session with polling disable for the following communication. User should end the session as soon as those communications finished.

Please note, this command may make the reader fail detect a card present/absence if used incorrectly. This fail may be unable to recover automatically until a logical/physical reader disconnection.

Command

Command	Class	INS	P1	P2	Lc	Data In	Le
Manage Session	FFh	C2h	00h	00h	Cmd Data Length	Cmd TLV	--/00h

Response Code

Rsp Data	SW1 SW2	Meaning
--	90 00h	The operation was completed successfully.
Rsp TLV	90 00h	For Le = 0x00, One of Command TLV Fail. For Detail of Error, refer to Rsp TLV.
--	6X XXh	For Le = --, One of Command TLV Fail.

Cmd TLV

Cmd	Meaning
Start Session: 81 00h	Start a Session and Disable Polling.
RF Off: 83 00h	Turn off RF.
Timer: 5F 46 04h [TIME]	Set the sleep time before the next RF On/Off TLV. [TIME]: 4 byte value (LSB first) in range from 1000 to 100000 us. The actual sleep time will round up to nearest 1000us.
RF On: 84 00h	Turn on RF.
End Session: 82 00h	End a Session and Re-enable Polling.

Rsp TLV

Rsp	Meaning
TLV Error: C0 03 NN 6X XXh	Error in the NN th Command TLV.



5.5.5.3.1. Start Session Data Object

This command is used to start a transparent session. Once the session has started, auto-polling will be disabled until the session is ended.

Start Session Data Object

Tag	Length (1 byte)	Value
81h	00h	-

5.5.5.3.2. End Session Data Object

This command ends the transparent session. The auto-polling will be reset to the state before the session has started.

End Session Data Object

Tag	Length (1 byte)	Value
82h	00h	-

5.5.5.3.3. Turn Off the RF Data Object

This command turns off the antenna field.

Turn off RF Field Data Object

Tag	Length (1 byte)	Value
83h	00h	-

5.5.5.3.4. Turn On the RF Data Object

This command turns on the antenna field.

Turn on the RF Field Data Object

Tag	Length (1 byte)	Value
84h	00h	-

5.5.5.3.5. Timer Data Object

This command creates a 32-bit timer data object in unit of 1 μ s.

Example: If there is a timer data object with 5000 μ s between RF Turn Off Data Object and RF Turn On Data Object, the reader will turn off the RF field for about 5000 μ s before it is turned on.

Timer Data Object

Tag	Length (1 byte)	Value
5F 46h	04h	Timer (4 bytes)



5.5.5.4. Transparent Exchange [FF C2 00 01 ...]

This command allows user transmit and receive any bit or bytes to/from card, with option to configure various link and transport layer (e.g. ISO14443 part 4) and some link layer redundancy (CRC and parity) optionally. User could embed any card specific raw data into this pseudo APDU and then send to the card.

Please note, this command may interference internal handling of card support, may change the card status without notification to the driver/firmware and may require a card reset and/or removal to bring the driver/firmware back to normal.

Command

Command	Class	INS	P1	P2	Lc	Data In	Le
Transparent Exchange	FFh	C2h	00h	01h	Cmd Data Length	Cmd TLV	00h

Response Code

Results	SW1 SW2	Meaning
Success	90 00h	The operation was completed successfully.
Error	6X XXh	Fail.

Cmd TLV

Cmd	Meaning
Transceive Flag: 90 02 [Flag] 00h	Set the Flag for the following Transceive TLV. Flag[7:5]: RFU; Set to 0 Flag[4]: Set to disable ISO14443 Part 4 Flag[3]: Set to disable receiving parity handling Flag[2]: Set to disable transmitting parity handling Flag[1]: Set to disable receiving CRC handling Flag[0]: Set to disable transmitting CRC handling If this TLV is missing, the Flag value set in previous command is used. If Flag value is never set, current protocol value is used.
Transmit Bit Frame: 91 01h [NumBit]	Set the Bit Frame for the following Transceive TLV. If this TLV is missing, the default value is 0. NumBit[7:3]: RFU; Set to 0 NumBit[2:0]: Number of valid bits in last byte (0 means all valid).
Timer: 5F 46 04h [TIME]	Set the timeout for the following Transceive TLV. [TIME]: 4 byte value (LSB first) in range 1 us to 1000000 us. The actual timeout will round up to nearest 302.07 x 20~15 us. If this TLV is missing, the FWTI value set previously will be used as timeout.
Set FWTI: FF 6E 03 03 01h [FWTI]	Set FWT/Timeout for Transceive. If FWTI does not set by any previous "FF C2h ..." command, the default value is 0.



Cmd	Meaning
	FWTI: 0 ~ 15, FWT/Timeout = 302.07 x 2FWTI us
Transceive: 95h [Size] [Data]	Size: Size of Data coded in BER-TLV length field. Data: Data to be Transmit.

Rsp TLV

Rsp	Meaning
Receive Bit framing: 92 01h [NumBit]	NumBit[7:3]: RFU; Set to 0. NumBit[2:0]: Number of valid bits in last byte (0 means all valid).
Response: 97h [Size] [Data]	Size: Size of Data coded in BER-TLV length field. Data: Data Received.
Response Status: 96 02h [Status] 00h	Status [7:4]: RFU. Status[3]: Framing Error. Status[2]: Parity Error. Status[1]: RFU. Status[0]: CRC Error.

5.5.5.4.1. Transmission and Reception Flag Data Object

This command defines the framing and RF parameters for the following transmission.

Transmission and Reception Flag Data Object

Tag	Length (1 byte)	Value		
		Byte 0		Byte 1
		bit	Description	
90h	02h	0	0 – append CRC in the transmit data 1 – do not append CRC in the transmit data	00h
		1	0 – CRC checking from the received data 1 – no CRC checking from the received data	
		2	0 – insert parity in the transmit data 1 – do not insert parity	
		3	0 – expect parity in received date 1 – do not expect parity (i.e. no parity checking)	
		4	0 – append protocol prologue in the transmit data or discard from the response 1 – do not append or discard protocol prologue if any (e.g. PCB, CID, NAD)	
		5-7	RFU	

5.5.5.4.2. Transmission Bit Framing Data Object

This command defines the number of valid bits of the last byte of data to transmit or transceive.

Transmission bit Framing Data Object

Tag	Length (1 byte)	Value	
		bit	Description
91h	01h	0-2	Number of valid bits of the last byte (0 means all bits are valid)



Tag	Length (1 byte)	Value	
		bit	Description
		3-7	RFU

Transmission bit framing data object shall be together with “transmit” or “transceive” data object only. If this data object does not exist, it means all bits are valid.

5.5.5.4.3. Transceive Data Object

This command transmits and receives data from the ICC. After transmission is complete, the reader will wait until the time given in the timer data object.

If no timer data object was defined in the data field, the reader will wait for the duration given in the Set Parameter FWTI Data Object. If no FWTI is set, the reader will wait for about 302 μs.

Transceive Data Object

Tag	Length	Value
95h	01-7Fh	Data (1~127 Bytes)
95h	81h	80h or above
		Data (128~N Bytes)

5.5.5.4.4. Timer Data Object

This command creates a 32-bit timer data object in unit of 1 μs.

Example: If there is a timer data object with 5000 μs, the reader will wait the following Transceive TLV for about 5000μs before timeout.

Timer Data Object

Tag	Length (1 byte)	Value
5F 46h	04h	Timer (4 bytes)

5.5.5.4.5. Response Bit Framing Data Object

Inside the response, this command is used to notify the received transmission bit Framing Data Object

Tag	Length (1 byte)	Value	
		bit	Description
92h	01h	0-2	Number of valid bits of the last byte (0 means all bits are valid)
		3-7	RFU

Transmission bit framing data object shall be together with “transmit” or “transceive” data object only. If this data object does not exist, it means all bits are valid.

5.5.5.4.6. Response Status Data Object

Inside the response, this command is used to notify the received data status.



Response Status Data Object

Tag	Length (1 byte)	Value		
		Byte 0		Byte 1
		Bit	Description	
96h	02h	0	0 – CRC is OK or no checked 1 – CRC check fail	RFU
		1	0 – no collision 1 – collision detected	
		2	0 – no parity error 1 – parity error detected	
		3	0 – no framing error 1 – framing error detected	
		4 - 7	RFU	

5.5.5.4.7. Response Data Object

Inside the response, this command is used to notify the received data status.

Response Data Object

Tag	Length (1 byte)	Value
97h	DataLen	ReplyData (N Byte)

5.5.5.5. Switch Protocol [FF C2 00 02 ...]

This command allows user to switch to specify protocol, select protocol layer and parameter.

Please note, this command may interference internal handling of card support, may change the card status without notification to the driver/firmware and may require a card reset and/or removal to bring the driver/firmware back to normal.

Command

Command	Class	INS	P1	P2	Lc	Data In	Le
Switch Protocol	FFh	C2h	00h	02h	Cmd Data Length	Cmd TLV	00h

Response Code

Rsp Data	SW1 SW2	Meaning
Rsp TLV	90 00h	Succeed with data.
--	90 00h	Succeed.
--	6X XXh	Fail.



Cmd TLV

Cmd	Meaning
Set Baud: FF 6E 03 05 01h [Baud]	Set the Baud for Part/Layer 4 to be applied during Switch Protocol. If [Baud] does not set by any previous "FF C2h ..." command, the default value is 98h (106 kbps). ISO14443: 98h (106 kbps), 99h (212 kbps), 9A (424 kbps), 9B (848 kbps). ISO15693: 80h (26 kbps), 08h (53 kbps)
Switch Protocol: 8F 02h [RF] [Layer]	Switch the protocol to specified RF and/or Layer. [RF]: 00h: ISO14443A, 01h: ISO14443B 02h: ISO15693, 03h: FeliCa, FFh: Current RF Other: RFU [Layer]: 02h: Layer/Part 2, 03h: Layer/Part 3, 04h: Layer/Part 4 (For A/B Only) Other: RFU Note: It must be in a Transparent Session (Disable Polling) if switching to Layer/Part 2.

Rsp TLV

Rsp	Meaning
Response: 8Fh [Size] [Data]	Size: Size of Data coded in BER-TLV length field. Data: ATR (if Part 4) or Final SAK (if Type A part 3) or PI in ATQB (if Type B part 3).

5.5.5.5.1. Switch Protocol Data Object

This command specifies the protocol and different layers of the standard.

Switch Protocol Data Object

Tag	Length (1 byte)	Value	
		Byte 0	Byte 1
8Fh	02h	00h – ISO/IEC14443 Type A 01h – ISO/IEC14443 Type B 02h - ISO15693 03h – FeliCa Other – RFU	02h – Switch to Layer 2 03h – Switch or activate to layer 3 04h – Activate to layer 4 Other - RFU



5.5.5.5.2. Response Data Object

Inside the response, this command is used to notify the received data status.

Response Data Object

Tag	Length (1 byte)	Value
5F 51h	DataLen	ATR
8Fh	DataLen	Final SAK (if Type A part 3) or PI in ATQB (if Type B part 3).

5.5.5.6. PCSC 2.0 Part 3 Example

- Start Transparent Session.
Command: **FF C2 00 00 02 81 00**
Response: **C0 03 00 90 00 90 00**
- Turn the Antenna Field off.
Command: **FF C2 00 00 02 83 00**
Response: **C0 03 00 90 00 90 00**
- Turn the Antenna Field on.
Command: **FF C2 00 00 02 84 00**
Response: **C0 03 00 90 00 90 00**
- ISO 14443-4A Active.
Command: **FF C2 00 02 04 8F 02 00 04**
Response: **C0 03 01 64 01 90 00** (if no card present)
C0 03 00 90 00 5F 51 [Len] [ATR] 90 00
- Set the PCB to 0Ah and enable the CRC, parity and protocol prologue in the transmit data.
Command: **FF C2 00 01 0A 90 02 00 00 FF 6E 03 07 01 0A**
Response: **C0 03 00 90 00 90 00**
- Send the APDU “80B2000008” to card and get response.
Command: **FF C2 00 01 0E 5F 46 04 40 42 0F 00 95 05 80 B2 00 00 08**
Response: **C0 03 00 90 00 92 01 00 96 02 00 00 97 0C [Card Response] 90 00**
- End Transparent Session.
Command: **FF C2 00 00 02 82 00**
Response: **C0 03 00 90 00 90 00**



5.5.6. Proprietary Pseudo APDU for PICC

The following Pseudo APDUs are provided as supplement to PCSC Pseudo APDUs to access a contactless card indirectly. The internally handling of these APDU is similar to PCSC Pseudo APDUs.

5.5.6.1. Write Value Block [FF D7 ...]

This command is used to write a 4-byte value to a block in a card compatible with MIFARE Standard. User should perform succeed authentication to get the access right of the block before sending this command.

Command

Command	Class	INS	P1	P2	Lc	Data In
Write Value Block	FFh	D7h	00h	Block Number	05h	See below

Command Data

Byte 0	Byte 1	Byte 2	Byte 3	Byte 4
00h	4 Bytes Value with MSB first			

Example 1: Decimal -4 = {FFh, FFh, FFh, FCh}

VB_Value			
MSB			LSB
FFh	FFh	FFh	FCh

Example 2: Decimal 1 = {00h, 00h, 00h, 01h}

VB_Value			
MSB			LSB
00h	00h	00h	01h

Response Code

Results	SW1 SW2	Meaning
Success	90 00h	The operation was completed successfully.
Error	6X XXh	Fail.



5.5.6.2. Read Value Block [FF B1 ...]

This command is used to read a 4-byte value from a valid value block in a card compatible with MIFARE Standard. User should perform succeed authentication to get the access right of the block before sending this command.

Command

Command	Class	INS	P1	P2	Le
Read Value Block	FFh	B1h	00h	Block Number	04h

Example 1: Decimal -4 = {FFh, FFh, FFh, FCh}

Value			
MSB			LSB
FFh	FFh	FFh	FCh

Example 2: Decimal 1 = {00h, 00h, 00h, 01h}

Value			
MSB			LSB
00h	00h	00h	01h

Response

Rsp Data	SW1 SW2	Meaning
4 Bytes Value with MSB first	90 00h	Succeed with data.
--	6X XXh	Fail.

5.5.6.3. Decrement/Increment Value [FF D7 ...]

This command is used to decrement/increment a 4-byte value from source block and stores the result to target block in a card compatible with MIFARE Standard. If user wants to store the result to the block same as source block, user can set the target block number equal to 0 or source block number. User should perform succeed authentication to get the access right of both source and target block before sending this command.

Command

Command	Class	INS	P1	P2	Lc	Data In
Decrement/Increment Value	FFh	D7h	Target Block#	Source Block#	05h	See below

Command Data

Byte 0	Byte 1	Byte 2	Byte 3	Byte 4
01h	4 Bytes Increment Value with MSB first			
02h	4 Bytes Decrement Value with MSB first			



Response Code

Results	SW1 SW2	Meaning
Success	90 00h	The operation was completed successfully.
Error	6X XXh	Fail.

5.5.6.4. Copy Value Block [FF D7 ...]

This command is used to copy the value from source block to target block in a card compatible with MIFARE Standard. User should perform succeed authentication to get the access right of both source and target block before sending this command.

Command

Command	Class	INS	P1	P2	Lc	Data In
Copy Value Block	FFh	D7h	00h	Source Block#	02h	See below

Command Data

Byte 0	Byte 1
03h	Target Block#

Response Code

Results	SW1 SW2	Meaning
Success	90 00h	The operation was completed successfully.
Error	6X XXh	Fail.



5.5.7. Accessing PCSC-Compliant tags (ISO14443-4)

All ISO 14443-4 compliant cards (PICCs) understand the ISO 7816-4 APDUs. The ACR1555U reader just has to communicate with the ISO 14443-4 compliant cards by exchanging ISO 7816-4 APDUs and responses. The ACR1555U will handle the ISO 14443 Parts 1-4 Protocols internally.

MIFARE Classic (1K/4K), MIFARE Mini and MIFARE Ultralight tags are supported through the T=CL emulation. Just simply treat the MIFARE tags as standard ISO 14443-4 tags. For more information, please refer to **PCSC Pseudo APDU (with Proprietary Extension) for PICC**.

ISO 7816-4 APDU Format

Command	Class	INS	P1	P2	Lc	Data In	Le
ISO 7816 Part 4 Command					Length of the Data In		Expected length of the Response Data

ISO 7816-4 Response Format (Data + 2 bytes)

Response	Data Out		
Result	Response Data	SW1	SW2

Common ISO 7816-4 Response Codes

Results	SW1 SW2	Meaning
Success	90 00h	The operation was completed successfully.
Error	63 00h	The operation failed.

Typical sequence may be:

1. Present the tag and connect the PICC Interface.
2. Read/Update the memory of the tag.

To do this:

1. Connect the tag.

The ATR of the tag is 3B 88 80 01 00 00 00 00 33 81 81 00 3Ah.

In which,

The Application Data of ATQB = 00 00 00 00, protocol information of ATQB = 33 81 81. It is an ISO 14443-4 Type B tag.

2. Send an APDU, Get Challenge.

<< 00 84 00 00 08h

>> 1A F7 F3 1B CD 2B A9 58h [90 00h]

Note: For ISO 14443-4 Type A tags, the ATS can be obtained by using the APDU "FF CA 01 00 00h."



Example:

```
// Read 8 bytes from an ISO 14443-4 Type B PICC (ST19XR08E)
```

```
APDU = {80 B2 80 00 08h}
```

```
Class = 80h
```

```
INS = B2h
```

```
P1 = 80h
```

```
P2 = 00h
```

```
Lc = None
```

```
Data In = None
```

```
Le = 08h
```

```
Answer: 00 01 02 03 04 05 06 07h [$9000h]
```

5.5.8. Accessing MIFARE DESFire (ISO 14443-3)

MIFARE® DESFire® supports ISO 7816-4 APDU Wrapping and Native modes. Once the MIFARE® DESFire® tag is activated, the first APDU command sent to the MIFARE® DESFire® tag will determine the “Command Mode”. If the first APDU is in “Native Mode”, the rest of the APDU commands must be in “Native Mode” format. Similarly, if the first APDU is “ISO 7816-4 APDU Wrapping Mode”, the rest of the APDUs must be in “ISO 7816-4 APDU Wrapping Mode” format.

Example 1: MIFARE® DESFire® ISO 7816-4 APDU Wrapping

```
// To read 8 bytes random number from an ISO 14443-4 Type A PICC (MIFARE® DESFire®)
```

```
APDU = {90 0A 00 00 01 00 00}
```

```
Class = 90h; INS = 0Ah (MIFARE DESFire Instruction); P1 = 00h; P2 = 00h
```

```
Lc = 01h; Data In = 00h; Le = 00h (Le = 00h for maximum length)
```

```
Answer: 7B 18 92 9D 9A 25 05 21 [$91AF]
```

Status Code {91 AF} is defined in the MIFARE® DESFire® specification. Please refer to the MIFARE® DESFire® specification for more details.

Example 2: MIFARE® DESFire® Frame Level Chaining (ISO 7816 wrapping mode)

```
// In this example, the application has to do the “Frame Level Chaining”.
```

```
// To get the version of the MIFARE® DESFire® card.
```

```
Step 1: Send an APDU {90 60 00 00 00} to get the first frame. INS=60h
```

```
Answer: 04 01 01 00 02 18 05 91 AF [$91AF]
```

```
Step 2: Send an APDU {90 AF 00 00 00} to get the second frame. INS=AFh
```



Answer: 04 01 01 00 06 18 05 91 AF [\$91AF]

Step 3: Send an APDU {90 AF 00 00 00} to get the last frame. INS=AFh

Answer: 04 52 5A 19 B2 1B 80 8E 36 54 4D 40 26 04 91 00 [\$9100]

5.5.9. Supported PICC ATR

The following PICC type/technology are supported by default. The following ATR is returned to CCID Host on PC_to_RDR_IccPowerOn Command or SCardStatus() in PCSC API if the card is presented to the reader.

Card Type/Technology	ATR
MIFARE Std 1k ⁵	3B 8F 80 01 80 4F 0C A0 00 00 03 06 03 00 01 00 00 00 00 6A
MIFARE Std 4k ⁵	3B 8F 80 01 80 4F 0C A0 00 00 03 06 03 00 02 00 00 00 00 69
MIFARE UltraLight ⁵	3B 8F 80 01 80 4F 0C A0 00 00 03 06 03 00 03 00 00 00 00 68
MIFARE Ultralight EV1 ⁵	3B 8F 80 01 80 4F 0C A0 00 00 03 06 03 00 3D 00 00 00 00 56
MIFARE Plus SL1 2k ⁵	Default: Same as MIFARE Std 1k Alternated: 3B 8F 80 01 80 4F 0C A0 00 00 03 06 03 00 36 00 00 00 00 5D
MIFARE Plus SL1 4k ⁵	Default: Same as MIFARE Std 4k Alternated: 3B 8F 80 01 80 4F 0C A0 00 00 03 06 03 00 37 00 00 00 00 5C
MIFARE Plus SL2 2k	3B 8F 80 01 80 4F 0C A0 00 00 03 06 03 00 38 00 00 00 00 53
MIFARE Plus SL2 4k	3B 8F 80 01 80 4F 0C A0 00 00 03 06 03 00 39 00 00 00 00 52
MIFARE UltraLight C ⁵	Default: 3B 8F 80 01 80 4F 0C A0 00 00 03 06 03 00 3A 00 00 00 00 51 Alternated: Same as MIFARE UltraLight
SmartMX with MIFARE Std 1k Emulation ⁵	Default: Same as MIFARE Std 1k Alternated: Same as ISO14443-4, Type A
SmartMX with MIFARE Std 4k Emulation ⁵	Default: Same as MIFARE Std 4k Alternated: Same as ISO14443-4, Type A
ISO14443-4, Type A	3B 8n 80 01 T1 .. Tn Tck n = Number of Historical bytes in ATS T1 .. Tn = Historical bytes in ATS Tck = XOR of 8n 80 01 T1 .. Tn

⁵ Refer to “Bit 3” and “Bit 7” in **Set Polling/ATR Option [E0 00 00 23 01 ...]** Escape command for configuration and drawback of the alternated ATR definition.



Card Type/Technology	ATR
ISO14443-4, Type B	3B 88 80 01 T1 .. T8 Tck T1 .. T4 = Application Data in ATQB T5 .. T7 = Protocol Info in ATQB T8 = MBLI in ATA Tck = XOR of 88 80 01 T1 .. T8
FeliCa	3B 8F 80 01 80 4F 0C A0 00 00 03 06 11 00 3B 00 00 00 00 42
ISO15693-3 Generic	3B 8F 80 01 80 4F 0C A0 00 00 03 06 0B 00 00 00 00 00 00 63
Infineon My-D Vicinity (SRF55Vxxx)	3B 8F 80 01 80 4F 0C A0 00 00 03 06 0B 00 0E 00 00 00 00 6D
ST LRI	3B 8F 80 01 80 4F 0C A0 00 00 03 06 0B 00 13 00 00 00 00 70
NXP I-Code SLI	3B 8F 80 01 80 4F 0C A0 00 00 03 06 0B 00 14 00 00 00 00 77
NXP I-Code SLIX/SLIX2	3B 8F 80 01 80 4F 0C A0 00 00 03 06 0B 00 35 00 00 00 00 56
PicoPass 2K	ISO14443B: 3B 8F 80 01 80 4F 0C A0 00 00 03 06 06 00 17 00 00 00 00 79
PicoPass 2KS	ISO14443B: 3B 8F 80 01 80 4F 0C A0 00 00 03 06 06 00 18 00 00 00 00 76
PicoPass 16K	ISO14443B: 3B 8F 80 01 80 4F 0C A0 00 00 03 06 06 00 19 00 00 00 00 77
PicoPass 16KS	ISO14443B: 3B 8F 80 01 80 4F 0C A0 00 00 03 06 06 00 1A 00 00 00 00 74
PicoPass 16K (8 x 2)	ISO14443B: 3B 8F 80 01 80 4F 0C A0 00 00 03 06 06 00 1B 00 00 00 00 75
PicoPass 16KS (8 x 2)	ISO14443B: 3B 8F 80 01 80 4F 0C A0 00 00 03 06 06 00 1C 00 00 00 00 72
PicoPass 32KS (16 + 16)	ISO14443B: 3B 8F 80 01 80 4F 0C A0 00 00 03 06 06 00 1D 00 00 00 00 73
PicoPass 32KS (16 + 8x2)	ISO14443B: 3B 8F 80 01 80 4F 0C A0 00 00 03 06 06 00 1E 00 00 00 00 70
PicoPass 32KS (8x2 + 16)	ISO14443B: 3B 8F 80 01 80 4F 0C A0 00 00 03 06 06 00 1F 00 00 00 00 71
PicoPass 32KS (8x2 + 8x2)	ISO14443B: 3B 8F 80 01 80 4F 0C A0 00 00 03 06 06 00 20 00 00 00 00 4E



In order to reduce response time for generic application, the support of following PICC type/technology are disabled by default. User could enable the support of each Type/Technology by “Set PICC Polling Type” Escape command. The following ATR is returned to CCID Host on PC_to_RDR_IccPowerOn Command or SCardStatus() in PCSC API if the card is presented to the reader and the corresponding Type/Technology is enabled.

Card Type/Technology	ATR
SRI (SRIX4K/SRT512)	3B 8F 80 01 80 4F 0C A0 00 00 03 06 06 00 07 00 00 00 00 69
Topaz	3B 8F 80 01 80 4F 0C A0 00 00 03 06 02 00 30 00 00 00 00 5A
PicoPass 2K	ISO15693: 3B 8F 80 01 80 4F 0C A0 00 00 03 06 0A 00 17 00 00 00 00 75
PicoPass 2KS	ISO15693: 3B 8F 80 01 80 4F 0C A0 00 00 03 06 0A 00 18 00 00 00 00 7A
PicoPass 16K	ISO15693: 3B 8F 80 01 80 4F 0C A0 00 00 03 06 0A 00 19 00 00 00 00 7B
PicoPass 16KS	ISO15693: 3B 8F 80 01 80 4F 0C A0 00 00 03 06 0A 00 1A 00 00 00 00 78
PicoPass 16K (8 x 2)	ISO15693: 3B 8F 80 01 80 4F 0C A0 00 00 03 06 0A 00 1B 00 00 00 00 79
PicoPass 16KS (8 x 2)	ISO15693: 3B 8F 80 01 80 4F 0C A0 00 00 03 06 0A 00 1C 00 00 00 00 7E
PicoPass 32KS (16 + 16)	ISO15693: 3B 8F 80 01 80 4F 0C A0 00 00 03 06 0A 00 1D 00 00 00 00 7F
PicoPass 32KS (16 + 8x2)	ISO15693: 3B 8F 80 01 80 4F 0C A0 00 00 03 06 0A 00 1E 00 00 00 00 7C
PicoPass 32KS (8x2 + 16)	ISO15693: 3B 8F 80 01 80 4F 0C A0 00 00 03 06 0A 00 1F 00 00 00 00 7D
PicoPass 32KS (8x2 + 8x2)	ISO15693: 3B 8F 80 01 80 4F 0C A0 00 00 03 06 0A 00 20 00 00 00 00 42
Innovatron	3B 88 80 01 80 4F 05 F0 49 4E 4E 4F 35
CTS	3B 87 80 01 80 4F 04 F0 43 54 53 79

6.0. Escape Command

The following commands are provided to configure PCD/NFC and to access special function of the reader. CCID Host could send these commands to reader by using CCID Message PC_to_RDR_Escape (corresponding to SCardControl() with SCARD_CTL_CODE(3500) in PCSC API). After receiving of an Escape Command, it will be interpreted to perform various operations and then generate a response to send back to CCID Host.

Note:

Should send these commands under correct interface. For example, E0 00 00 25 01 00 (Section 6.1.1) should send through PICC interface (Section 6.0).

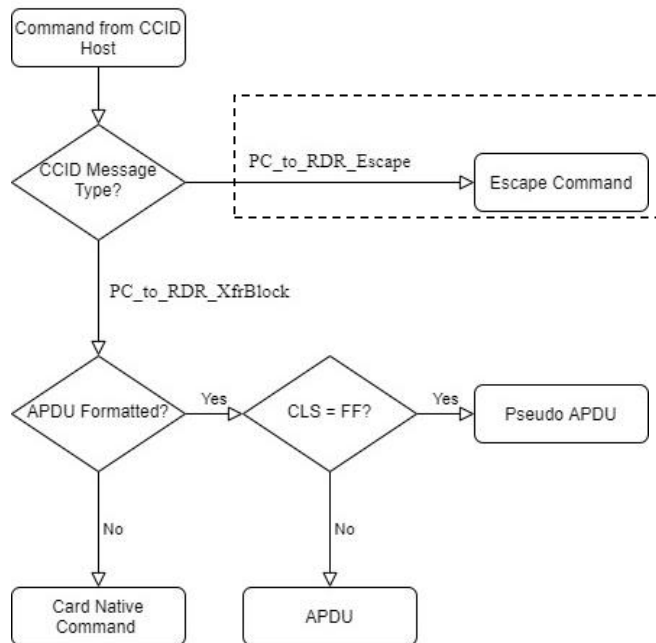

Below escape commands can be executed without mutual authentication.

Description	Escape Command
Get Firmware Version	E0 00 00 18 00
Get Serial Number	E0 00 00 47 00
Get BLE Advertising Name	E0 00 00 44 00
Read BLE Communication Mode	E0 00 00 77 00

Table 15: Executable Escape Commands without Mutual Authentication



6.1. Escape Command for PICC

6.1.1. RF Control [E0 00 00 25 01 ...]

This command is used to set the RF control.

Command

Command	Class	INS	P1	P2	Lc	Data Out
RF Control	E0h	00h	00h	25h	01h	RF status

Response Code

Response	Class	INS	P1	P2	Le	Data In
Result	E1h	00h	00h	00h	01h	RF status

RF Status: 1 Byte

RF status	Description
00h	RF Off
01h	RF On, with Polling
02h	RF On, without Polling

Default Setting – 01h (RF On, with Polling)

6.1.2. Get PCD/PICC Status [E0 00 00 25 00]

This command is used to get the PCD/PICC status

Command

Command	Class	INS	P1	P2	Le
Get PCD/PICC Status	E0h	00h	00h	25h	00h

Response Code

Response	Class	INS	P1	P2	Le	Data In
Result	E1h	00h	00h	00h	01h	Get PCD/PICC Status

PCD/PICC Status: 1 Byte

RF status	Description
00h	RF Off
01h	No PICC
02h	PICC Ready
03h	PICC Selected/Activated
FFh	Error

6.1.3. Get Polling/ATR Option [E0 00 00 23 00]

This command is used to set/get the Polling Option but save the setting without another command. This command should only be used for initial reader configuration.

Command

Command	Class	INS	P1	P2	Le
Get Polling/ATR Option	E0h	00h	00h	23h	00h



Response Code

Response	Class	INS	P1	P2	Le	Data In
Result	E1h	00h	00h	03h	01h	PICC Polling/ATR Option

6.1.4. Set Polling/ATR Option [E0 00 00 23 01 ...]

This command is used to set the polling option.

Command

Command	Class	INS	P1	P2	Lc	Data Out
Set Polling/ATR Option	E0h	00h	00h	23h	01h	PICC Polling/ATR Option

Response Code

Response	Class	INS	P1	P2	Le	Data In
Result	E1h	00h	00h	00h	01h	PICC Polling/ATR Option

PICC Polling/ATR Option - 1 Byte

Operating Parameter	Parameter	Description	Option
Bit 0	Enable Polling	The Tag Types to be detected during PICC Polling.	1 = Detect 0 = Skip
Bit 1	Enable RF Off Interval		
Bit 2	RFU		
Bit 3	Enable extra MIFARE type identification for Part 3 card in ATR	The Tag Types to be detected during PICC Polling.	1 = Detect 0 = Skip
Bit 4 ~ 5	RF Off Interval		
Bit 6	RFU		
Bit 7	Enable Part 4 ATR for SmartMX/JCOS card with MIFARE emulation	The Tag Types to be detected during PICC Polling.	1 = Detect 0 = Skip

RF Off Interval – 2 Bit **Case 1:** Disabled RF Off Interval (Bit 1 = 0)

Operating Parameter		USB Active (D0)
Bit 5	Bit 4	
0	0	No RF Off
0	1	
1	0	
1	1	

Case 2: Enabled RF Off Interval (Bit 1 = 1)

Operating Parameter		USB Active (D0)
Bit 5	Bit 4	
0	0	250 ms
0	1	500 ms
1	0	1000 ms
1	1	2500 ms

Default Setting – 8Bh (Enabled Polling, Enabled RF Off, Enabled extra MIFARE type identification for Part 3 card in ATR, RF Off Interval[00], Enabled Part 4 ATR for SmartMX/JCOS card with MIFARE emulation)



6.1.5. Get PICC Polling Type [E0 00 01 20 00]

This command is used to get the allowed Technology/Polling Type but save the setting without another command. This command should only be used for initial reader configuration.

Command

Command	Class	INS	P1	P2	Le
Get PICC Polling Type	E0h	00h	01h	20h	00h

Response Code

Response	Class	INS	P1	P2	Le	Data In
Result	E1h	00h	00h	00h	02h	PICC Polling Type

6.1.6. Set PICC Polling Type [E0 00 01 20 02 ...]

This command is used to set the PICC polling type.

Command

Command	Class	INS	P1	P2	Lc	Data Out	
						Byte 1	Byte 0
Set PICC Polling Type	E0h	00h	01h	20h	02h	PICC Polling Type	

Response Code

Response	Class	INS	P1	P2	Le	Data In	
						Byte 1	Byte 0
Result	E1h	00h	00h	00h	02h	PICC Polling Type	

PICC Polling Type - 2 Byte, Bit Mask of following

Bytes	Operating Parameter	Parameter	Description	Option
Byte 1	Bit 0	ISO 14443A	The Tag Types to be detected during PICC Polling. RFU bit should be set to 0.	1 = Detect 0 = Skip
	Bit 1	ISO 14443B		
	Bit 2	FeliCa 212Kbps		
	Bit 3	FeliCa 424Kbps		
	Bit 4	Topaz ⁽¹⁾		
	Bit 5	Innovatron		
	Bit 6	SRI/SRIX		
Byte 0	Bit 7	RFU		
	Bit 0	Picopass (ISO14443B)		
	Bit 1	Picopass (ISO15693)		



Bytes	Operating Parameter	Parameter	Description	Option
	Bit 2	ISO15693		
	Bit 3	CTS		
	Bit 4-7	RFU		

⁽¹⁾Supported by firmware version 1.03.00 or later

Default Setting – Byte 1: 07h (ISO14443A, ISO14443B, FeliCa 212Kbps)

Byte 0: 05h (Picopass (ISO14443B), ISO15693)

Example:

Command: E0 00 01 20 02 07 05

Response: E1 00 00 00 02 07 05

Polling Type: Byte 1 = 07h = 0000 0111b = ISO14443A, ISO14443B, FeliCa 212Kbps

Byte 0 = 05h = 0000 0101b = Picopass (ISO14443B), ISO15693

6.1.7. Get Auto PPS [E0 00 00 24 00]

Whenever a PICC is recognized, the reader will try to change the communication speed between the PCD and PICC as defined by the maximum connection speed. If the card does not support the proposed connection speed, the reader will try to connect the card with a slower speed setting.

Command

Command	Class	INS	P1	P2	Le
Get Auto PPS	E0h	00h	00h	24h	00h

Response Code

Response	Class	INS	P1	P2	Le	Data In	
Result	E1h	00h	00h	00h	02h	Max Speed	Current Speed

6.1.8. Set Auto PPS [E0 00 00 24 01 ...]

This command is used to set the auto PPS.

Command

Command	Class	INS	P1	P2	Lc	Data Out
Set Auto PPS	E0h	00h	00h	24h	01h	Max Speed

Response Code

Response	Class	INS	P1	P2	Le	Data In	
Result	E1h	00h	00h	00h	02h	Max Speed	Current Speed

Speed of PPS



Speed	Description
00h	106 kbps; equal to No Auto PPS
01h	212 kbps
02h	424 kbps
03h	848 kbps

Default Setting – 02h (424 kbps)

Notes:

1. Normally, the application should know the maximum connection speed of the PICCs being used. The environment also affects the maximum achievable speed. The reader just uses the proposed communication speed to talk with the PICC. The PICC will become inaccessible if the PICC or environment does not meet the requirement of the proposed communication speed.

2. If the higher speed setting affects the performance of the reader, please switch back to a lower speed setting.

6.1.9. Read PICC Type [E0 00 00 35 00]

This command is used to read the PICC type.

command

Command	Class	INS	P1	P2	Le
Get PICC Type	E0h	00h	00h	35h	00h

Response Code

Response	Class	INS	P1	P2	Le	Data In	
Result	E1h	00h	00h	00h	02h	Type	Status

Type: 1 Byte

Type	Description
CCh	No PICC
04h	Topaz
10h	MIFARE
11h	FeliCa
20h	Type A, Part 4
23h	Type B, Part 4
25h	Innovatron
28h	SRIX
30h	PicoPass
FFh	Other

Status: 1 Byte



Status	Description
00h	RF Off
01h	No PICC
02h	PICC Ready
03h	PICC Selected/Activated
FFh	Error

6.1.10. Escape Command for PICC – HID Keyboard

6.1.10.1. Get Output Format [E0 00 00 90 00]

This command is used to get output format.

Command

Command	Class	INS	P1	P2	Le
Get Output Format	E0h	00h	00h	90h	00h

Response Code

Response	Class	INS	P1	P2	Le	Data In	
Result	E1h	00h	00h	00h	02h	Output Format	Output Order

6.1.10.2. Set Output Format [E0 00 00 90 02 ...]

This command is used to set output format.

Command

Command	Class	INS	P1	P2	Lc	Data Out	
Set Output Format	E0h	00h	00h	90h	02h	Output Format	Output Order

Response Code

Response	Class	INS	P1	P2	Le	Data In	
Result	E1h	00h	00h	00h	02h	Output Format	Output Order

Output Format: 1 Byte

Operating Parameter	Parameter	Description	Option
Bit 7 ~ 4	Letter Case	The Tag Types to be detected during PICC Polling.	1 = Detect 0 = Skip
Bit 3 ~ 0	Display Mode		



Output Order: 1 Byte

Status	Description
00h	Default setting (UID Byte 0, UID Byte 1 ... UID Byte N) Example: aa cc bb dd (original /actual UID order)
01h	Reverse all card type order (UID Byte N, UID Byte N-1 ... UID Byte 0) Example: dd bb cc aa (reverse the original / actual UID order)
02h	Reverse ISO 14443 and Felica only Example: dd bb cc aa (reverse the selected Card Type original / actual UID order)
04h	Reverse ISO 15693 only Example: dd bb cc aa (reverse the selected Card Type original / actual UID order)

Letter Case: Upper 4 Bits (Bit 7 ~ 4)

Status (From bit 7~4)	Description (Don't care about x bit)
1xxx	Reserved
00x0	Lowercase
00x1	Uppercase
000x	Only Support 4 bytes UID
001x	Support 4, 7, 8, 10 bytes UID

Display Mode: Lower 4 Bits (Bit 3 ~ 0)

Status (From bit 7~4)	Description (Don't care about x bit)
0h	Hex
1h	Dec (byte by byte)
2h	Dec
3h	6H-6H
4h	8H-8H
5h	10H-10H
6h	14H-14H
7h	20H-20H
8h	6H-8D
9h	6H-10D



Status (From bit 7~4)	Description (Don't care about x bit)
Ah	8H-10D
Bh	10H-14D
Ch	2H4H-8D
Dh	14H-17D

Default Setting – Output Format: 30h

Output Order: 00h

6.1.10.3. Get Character at Start, Between, at End UID [E0 00 00 91 00]

This command is used to get character at Start, Between, End UID.

Command

Command	Class	INS	P1	P2	Le
Get Character of UID	E0h	00h	00h	91h	00h

Response Code

Response	Class	INS	P1	P2	Le	Data In		
Result	E1h	00h	00h	00h	03h	Between	End	Start

6.1.10.4. Set Character at Start, Between, at End UID [E0 00 00 91 03 ...]

This command is used to set character at Start, Between, End UID.

Command

Command	Class	INS	P1	P2	Lc	Data Out		
Set Character of UID	E0h	00h	00h	91h	03h	Between	End	Start

Response Code

Response	Class	INS	P1	P2	Le	Data In		
Result	E1h	00h	00h	00h	03h	Between	End	Start

Between: 1 Byte (The character between each UID)

Status	Description
FFh	No character in between
Other	Refer to Universal Serial Bus (USB) HID Usage Tables



End: 1 Byte (The character at the end of output)

Status	Description
FFh	No character in between
Other	Refer to Universal Serial Bus (USB) HID Usage Tables

Start: 1 Byte (The character at the start of output)

Status	Description
FFh	No character in between
Other	Refer to Universal Serial Bus (USB) HID Usage Tables

Default Setting – Between: 2Ch (Space)

End: 28h (Enter)

Start: FFh (No character)

Notes:

- only the characters “;” “,” “.” “/” “-” are supported in the AZERTY keyboard layout for the characters in between. Zero (0) and Backspace are NOT supported.

6.1.10.5. Get Keyboard Layout Language [E0 00 00 92 00]

This command is used to get keyboard layout language.

Command

Command	Class	INS	P1	P2	Le
Get Keyboard Layout Language	E0h	00h	00h	92h	00h

Response Code

Response	Class	INS	P1	P2	Le	Data In
Result	E1h	00h	00h	00h	01h	Keyboard Layout Language

6.1.10.6. Set Keyboard Layout Language [E0 00 00 92 01 ...]

This command is used to set keyboard layout language.

Command

Command	Class	INS	P1	P2	Lc	Data Out
Set Keyboard Layout Language	E0h	00h	00h	92h	01h	Keyboard Layout Language

Response Code

Response	Class	INS	P1	P2	Le	Data In
Result	E1h	00h	00h	00h	01h	Keyboard Layout Language



Keyboard Layout Language: 1 Byte

Status	Description
00h	English
01h	French
02h	Reserved
03h	Lithuanian

Default Setting – 00h (English)

6.1.10.7. Get Host Interface [E0 00 00 93 00]

This command is used to get host interface

Command

Command	Class	INS	P1	P2	Le
Get Host Interface	E0h	00h	00h	93h	00h

Response Code

Response	Class	INS	P1	P2	Le	Data In
Result	E1h	00h	00h	00h	01h	Host Interface

6.1.10.8. Set Host Interface [E0 00 00 93 01 ...]

This command is used to set host interface.

Notice: The reader would automatically power off to apply the setting.

Command

Command	Class	INS	P1	P2	Lc	Data Out
Set Host Interface	E0h	00h	00h	93h	01h	Host Interface

Response Code

Response	Class	INS	P1	P2	Le	Data In
Result	E1h	00h	00h	00h	01h	Host Interface

Host Interface: 1 Byte



Status	Description
00h	Only HID Keyboard
01h	Only CCID Reader

Default Setting – 01h (Only CCID Reader)

6.1.10.9. Get On-Screen Keyboard Setting[E0 00 00 94 00]

This command is used to get on-screen keyboard behaviour.

Note: This setting controls whether the on-screen keyboard pops up when the ACR1555U is connected to an iOS device in HID keyboard emulation mode. It is supported only on iOS devices and is applicable to firmware version 1.02.09 and later.

Command

Command	Class	INS	P1	P2	Lc
Get On-Screen Keyboard Setting	E0h	00h	00h	94h	00h

Response Code

Response	Class	INS	P1	P2	Le	Data In
Result	E1h	00h	00h	00h	01h	On-Screen Keyboard Setting

6.1.10.10. Set On-Screen Keyboard Setting[E0 00 00 94 01 ...]

This command is used to set on-screen keyboard behaviour. This setting only supported IOS device

Note: This setting controls whether the on-screen keyboard pops up when the ACR1555U is connected to an iOS device in HID keyboard emulation mode. It is supported only on iOS devices and is applicable to firmware version 1.03.00 and later.

Command

Command	Class	INS	P1	P2	Lc	Data Out
Set On-Screen Keyboard Setting	E0h	00h	00h	94h	01h	On-Screen Keyboard Setting

Response Code

Response	Class	INS	P1	P2	Le	Data In
Result	E1h	00h	00h	00h	01h	On-Screen Keyboard Setting

On-Screen Keyboard Setting: 1 Byte

Status	Description
00h	Disable Keyboard Popup
01h	Enable Keyboard Popup

Default Setting – 00h (Disable Keyboard Popup)



6.1.11. Escape Command for PICC – Card Emulation

6.1.11.1. Enter Card Emulation Mode [E0 00 00 40 03 ...]

This command is used to set the reader into card emulation mode in order to emulate a NFC Forum Type 2 Tag or a FeliCa Card.

Note: Lock byte is not supported in emulated NFC Forum Type 2 Tag. UID is user programmable.

Command

Command	Class	INS	P1	P2	Lc	Data Out		
Enter Card Emulation Mode	E0h	00h	00h: Temperate 01h: Permeate	40h	03h	NFC Mode	00h	00h

Response Code

Response	Class	INS	P1	P2	Le	Data In
Result	E1h	00h	00h	00h	03h	NFC Mode

NFC Device Mode: 3 Byte

Status	Description
02h	NFC Forum Type 2 Tag Mode
03h	FeliCa
Other	Card Read/Write Mode

Note: Please enter to Card Read/Write mode before switching to different card emulation mode. The response will be showed after the Card Emulation Mode initial is done.

Byte Number	0	1	2	3	Byte Address access by USB
Serial Number	SN0	SN1	SN2	SN3	Nil
Reserved	Reserved	Reserved	Reserved	Reserved	Nil
Internal/Lock	Reserved	Internal	Lock0	Lock1	Nil
Data read/write	Data0	Data1	Data2	Data3	0-3
Data read/write	Data4	Data5	Data6	Data7	4-7
Data read/write	Data8	Data9	Data10	Data11	8-11
Data read/write	Data12	Data13	Data14	Data15	12-15
Data read/write	Data16	Data17	Data18	Data19	16-19
Data read/write	Data20	Data21	Data22	Data23	20-23
Data read/write	Data24	Data25	Data26	Data27	24-27
Data read/write	Data28	Data29	Data30	Data31	28-31
Data read/write	Data32	Data33	Data34	Data35	32-35
Data read/write	Data36	Data37	Data38	Data39	36-39
Data read/write	Data40	Data41	Data42	Data43	40-43
Data read/write	Data44	Data45	Data46	Data47	44-47
Data read/write	Data48	Data49	Data50	Data51	48-51
Data read/write	Data52	Data53	Data54	Data55	52-55
Data read/write	
Data read/write	Data1984	Data1985	Data1986	Data1987	1984-1987

Accessible area (1988 bytes)

Table 15: NFC Forum Type 2 Tag Memory Map (2000 bytes)



Memory	1 Block data (16 Byte)	Byte Address access by USB
Data read/write	Block 0	0-15
Data read/write	Block 1	16-31
Data read/write	Block 2	32-47
Data read/write	Block 3	48-63
Data read/write	Block 4	64-79
Data read/write	Block 5	80-95
Data read/write	Block 6	96-111
Data read/write	Block 7	112-127
Data read/write	Block 8	128-143
Data read/write	Block 9	144-159

Table 16: FeliCa Memory Map (160 bytes)

Where:

Default: Block 0 data: {10h, 01h, 01h, 00h, 09h, 00h, 00h, 00h, 00h, 00h, 01h, 00h, 00h, 00h, 00h, 1Ch}

Default Block 0 data NFC Type3 Tag Attribute Information Block

Notes:

1. FeliCa card emulation support Read/Write without Encryption
2. FeliCa Card Identification Number in IDm is user programmable while Manufacturer Code is fixed at (03 88).

6.1.11.2. Read Card Emulation Data (NFC Forum Type 2 Tag) [E0 00 00 60 04 ...]

This command is used to read the emulated card content.

Command

Command	Class	INS	P1	P2	Lc	Data In			
Read Card Emulation Data	E0h	00h	00h	60h	04h	00h	NFC Mode	Start Offset	Length

Response Code

Response	Class	INS	P1	P2	Le	Data In
Result	E1h	00h	00h	00h	Length	Data

Start Offset: 1 Byte – Address start from Data0 in **Table 15**

Length: 1 Byte – No. of byte



6.1.11.3. Write Card Emulation Data (NFC Forum Type 2 Tag) [E0 00 00 60 ...]

This command is used to write the emulated card content.

Command

Command	Class	INS	P1	P2	Lc	Data In				
Write Card Emulation Data	E0h	00h	00h	60h	Length + 04h	01h	NFC Mode	Start Offset	Length	Data

Response Code

Response	Class	INS	P1	P2	Le	Data In				
Result	E1h	00h	00h	00h	03h	Length	90h	00h		

NFC Device Mode: 1 Byte

Status	Description
02h	NFC Forum Type 2 Tag Mode
03h	FeliCa
Other	Card Read/Write Mode

Start Offset: 1 Byte – Address start from Data0 in **Table 15**

Length: 1 Byte – No. of byte

6.1.11.4. Read Card Emulation Data (NFC Forum Type 2 Tag) (Extended)

This command is used to read the emulated card content.

Command

Command	Class	INS	P1	P2	Lc	Data In				
Read Card Emulation Data	E0h	00h	01h	60h	05h	00h	NFC Mode	Start Offset Bit[15:8]	Start Offset Bit[7:0]	Length

Response Code

Response	Class	INS	P1	P2	Le	Data In				
Result	E1h	00h	00h	00h	Length	Data				

Start Offset: 2 Byte – Address start to read from SN0 in **Table 15**

Length: 1 Byte – No. of byte to read

6.1.11.5. Write Card Emulation Data (NFC Forum Type 2 Tag) (Extended)

This command is used to write the emulated card content.

Command

Command	Class	INS	P1	P2	Lc	Data In					
Write Card Emulation Data	E0h	00h	01h	60h	Length + 05h	01h	NFC Mode	Start Offset Bit[15:8]	Start Offset Bit[7:0]	Length	Data



Response Code

Response	Class	INS	P1	P2	Le	Data In		
Result	E1h	00h	00h	00h	03h	Length	90h	00h

NFC Device Mode: 1 Byte

Status	Description
02h	NFC Forum Type 2 Tag Mode
Other	Card Read/Write Mode

Start Offset: 2 Byte – Address start to write from SN0 in **Table 15**

Length: 1 Byte – No. of byte to write

6.1.11.6. Set Card Emulation of NFC Forum Type 2 Tag ID [E0 00 00 61 03 ...]

This command sets the UID of the emulated MIFARE Ultralight card.

Command

Command	Class	INS	P1	P2	Lc	Data In
Set Card Emulation Lock Data	E0h	00h	00h	61h	03h	3 bytes UID

Response Code

Response	Class	INS	P1	P2	Le	Data In	
Result	E1h	00h	00h	00h	02h	90h	00h

6.1.11.7. Set Card Emulation Lock Data in NFC [E0 00 00 65 01 ...]

This command sets the lock for card emulation data in NFC communication. If the data is locked, it is protected from being overwritten via NFC.

Command

Command	Class	INS	P1	P2	Lc	Data In
Set Card Emulation Lock Data	E0h	00h	00h	65h	01h	Lock

Response Code

Response	Class	INS	P1	P2	Le	Data In
Result	E1h	00h	00h	00h	01h	Lock

Lock: 1 Byte – Protect the data from being overwritten via NFC

Operating Parameter	Parameter	Description	Option
Bit 7 ~ 2	Reserved	Reserved	
Bit 1	FeliCa Lock Enable	Data cannot be modified via NFC. The data can still be modified by using the USB escape command.	0: Lock disable 1: Lock enable
Bit 0	NFC Forum Type 2 Tag Enable		



6.1.11.8. Set Card Emulation FeliCa IDm [E0 00 00 64 06 ...]

This command sets the 6-byte FeliCa Card Identification number on emulated FeliCa card.

Command

Command	Class	INS	P1	P2	Lc	Data In
Set Card Emulation FeliCa IDm	E0h	00h	00h	64h	06h	IDm

Response Code

Response	Class	INS	P1	P2	Le	Data Out
Result	E1h	00h	00h	00h	06h	IDm

Where:

IDm 6 bytes.

6.1.11.9. Get Card Emulation Status [E0 00 00 69 00]

This command is used to get the status of card emulation data in NFC communication.

Command

Command	Class	INS	P1	P2	Lc
Get Card Emulation Status	E0h	00h	00h	69h	00h

Response Code

Response	Class	INS	P1	P2	Le	Data In
Result	E1h	00h	00h	00h	01h	Status

Status: 1 Byte

Operating Parameter	Mode	Description
Bit 7 ~ 6	Reserved	Reserved
Bit 5	EmulatedCard is activated	1 = Activated
Bit 4	EmulatedCard is removed	1 = Card is removed
Bit 3	EmulatedCard is read all	1 = All data is read
Bit 2	EmulatedCard is read	1 = Data is read
Bit 1	EmulatedCard is written	1 = Data is written
Bit 0	EmulatedCard is detected	1 = Card is detecting



6.1.11.10. Example Command Set of Emulating NFC Forum Type 2 Tag Mode

The command set is to trigger ACS website <https://www.acs.com.hk> by using ACR1555U to emulate as the NFC forum type 2 tag mode. The steps are showed below:

1. Enter the card emulation mode with below command:
 - Send Enter Card Emulation Mode
E0 00 00 40 03 02 00 00
2. Write the NDEF data with below command:
 - Send Write Card Emulation Data (NFC Forum Type 2 Tag)
E0 00 00 60 1A 01 02 00 16 E1 10 F4 00 03 0F D1 01 0B 55 02 61 63 73 2E 63 6F 6D 2E 68 6B FE

The command set is to trigger an sample long URL website

<https://www.example.com/this/is/a/very/long/url/that/keeps/going/on/and/on/with/even/more/segments/added/to/make/sure/it/exceeds/the/typical/length/limit/of/260/bytes/which/is/surprisingly/easy/to/do/if/you/keep/adding/more/and/more/segments/like/this/one/and/even/more>

by using ACR1552U to emulate as the NFC forum type 2 tag mode. The steps are showed below:

1. Enter the card emulation mode with below command:
 - Send Enter Card Emulation Mode
E0 00 00 40 03 02 00 00
2. Write the NDEF data with below command:
 - Send Write Card Emulation Data (NFC Forum Type 2 Tag). Since the length of the NDEF message is longer than 256 bytes, it needs to be spilt into two parts to send to the NFC Forum Type 2 Tag.
E0 00 00 60 AC 01 02 00 A8 E1 10 F4 00 03 FF 01 09 C1 01 00 00 01 02 55 02 65 78 61 6D 70 6C 65 2E 63 6F 6D 2F 74 68 69 73 2F 69 73 2F 61 2F 76 65 72 79 2F 6C 6F 6E 67 2F 75 72 6C 2F 74 68 61 74 2F 6B 65 65 70 73 2F 67 6F 69 6E 67 2F 6F 6E 2F 61 6E 64 2F 6F 6E 2F 77 69 74 68 2F 65 76 65 6E 2F 6D 6F 72 65 2F 73 65 67 6D 65 6E 74 73 2F 61 64 64 65 64 2F 74 6F 2F 6D 61 6B 65 2F 73 75 72 65 2F 69 74 2F 65 78 63 65 65 64 73 2F 74 68 65 2F 74 79 70 69 63 61 6C 2F 6C 65 6E 67 74 68 2F 6C 69 6D 69 74 2F 6F 66 2F 32 36 30 2F 62 79 74
E0 00 00 60 6E 01 02 A8 6A 65 73 2F 77 68 69 63 68 2F 69 73 2F 73 75 72 70 72 69 73 69 6E 67 6C 79 2F 65 61 73 79 2F 74 6F 2F 64 6F 2F 69 66 2F 79 6F 75 2F 6B 65 65 70 2F 61 64 64 69 6E 67 2F 6D 6F 72 65 2F 61 6E 64 2F 6D 6F 72 65 2F 73 65 67 6D 65 6E 74 73 2F 6C 69 6B 65 2F 74 68 69 73 2F 6F 6E 65 2F 61 6E 64 2F 65 76 65 6E 2F 6D 6F 72 65 FE

Notes:

For more detailed information and specifications related to the NDEF (NFC Data Exchange Format), I would recommend referring to the NDEF specification. It provides comprehensive guidelines and details about the structure and usage of NDEF records, which are commonly used in NFC data exchange. The NDEF specification will provide a deeper understanding of how to interpret and utilize the NDEF command and data in the context of the ACR1555U device.



6.2. Escape Command for ICC

6.2.1. Get Card Power Configuration [E0 00 00 0B 00]

This command is used get the ICC Card Power Configuration. This command should only be used for initial reader configuration.

Command

Command	Class	INS	P1	P2	Le
Get Card Power Configuration	E0h	00h	00h	0Bh	00h

Response Code

Response	Class	INS	P1	P2	Le	Data In
Result	E1h	00h	00h	00h	01h	Card Power Config

6.2.2. Set Card Power Configuration [E0 00 00 0B 01 ...]

This command is used set and save the ICC Card Power Configuration. This command should only be used for initial reader configuration.

Command

Command	Class	INS	P1	P2	Lc	Data Out
Set Card Power Configuration	E0h	00h	00h	0Bh	01h	Config

Response Code

Response	Class	INS	P1	P2	Le	Data In
Result	E1h	00h	00h	00h	01h	Card Power Config

Card Power Config (1 byte)

Card Power Config	Description
00h	Auto Detect, 1.8V -> 3V -> 5V
01h	5V Only
02h	3V Only
03h	1.8V Only
04h	Auto Detect, 5V -> 3V -> 1.8V
Other	RFU

Default Setting – 04h (Auto Detect, 5V -> 3V -> 1.8V)



6.3. Escape Command for Peripheral Control and Other

6.3.1. Get Firmware Version [E0 00 00 18 00]

This command is used to get reader's firmware message.

Command

Command	Class	INS	P1	P2	Le
Get Firmware Version	E0h	00h	00h	18h	00h

Response Code

Response	Class	INS	P1	P2	Le	Data In
Result	E1h	00h	00h	00h	Length of Firmware Version	Firmware Version

Example:

Command: E0 00 00 18 00

Response Code: E1 00 00 00 12 41 43 52 31 35 35 35 20 46 57 20 31 2E 30 30 2E 30 30

Firmware Version in Hex: 41 43 52 31 35 35 35 20 46 57 20 31 2E 30 30 2E 30 30

Firmware Version in ASCII: ACR1555 FW 1.00.00

6.3.2. Get Serial Number [E0 00 00 47 00]

This command is used to get the serial number.

Command

Command	Class	INS	P1	P2	Le
Get Serial Number	E0h	00h	00h	47h	00h

Response Code

Response	Class	INS	P1	P2	Le	Data out
Result	E1h	00h	00h	00h	Length of Serial No.	Serial No.



6.3.3. Set S/N in USB Descriptor [E0 00 00 F0]

This command is used to Set S/N in USB Descriptor.

Command

Command	Class	INS	P1	P2	Le	Data In	
Set S/N in USB Descriptor	E0h	00h	00h	F0h	02h	00h	Enable SN in USB Descriptor

Response Code

Response	Class	INS	P1	P2	Le	Data Out		
Result	E1h	00h	00h	00h	03h	Enable SN in USB Descriptor	90h	00h

Enable SN in USB Descriptor (1 byte)

Enable SN in USB Descriptor	Description
00h	Disable SN in USB Descriptor
01h	Enable SN in USB Descriptor

6.3.4. Set Buzzer Control - Single Time [E0 00 00 28 01 ...]

This command is used to set a single buzzer

Command

Command	Class	INS	P1	P2	Lc	Data Out
Buzzer Control	E0h	00h	00h	28h	01h	BUZ Status

Response Code

Response	Class	INS	P1	P2	Le	Data In
Result	E1h	00h	00h	00h	01h	BUZ Status

Buzzer Status (1 byte)

Buzzer Status	Description
00h	Off
01 ~ FFh	On with duration in 10ms unit



6.3.5. Set Buzzer Control - Repeatable [E0 00 00 28 03 ...]

This command is used to set period of buzzer

Command

Command	Class	INS	P1	P2	Lc	Data Out
Buzzer Control	E0h	00h	00h	28h	03h	BUZ Status

Response Code

Response	Class	INS	P1	P2	Le	Data In
Result	E1h	00h	00h	00h	03h	BUZ Status

Buzzer Status (3 byte)

Operating Parameter	Buzzer Status	Description
Param 1 – Byte 0	On Time Period	01 ~ FF: On Duration in 10ms unit
Param 2 – Byte 1	Off Time Period	01 ~ FF: Off Duration in 10ms unit
Param 3 – Byte 2	Time for Repeating	01 ~ FF: Number to Repeat

6.3.6. Get LED Status [E0 00 00 29 00]

This command is used to get the current LED status

Command

Command	Class	INS	P1	P2	Le
Get LED Status	E0h	00h	00h	29h	00h

Response Code

Response	Class	INS	P1	P2	Le	Data In
Result	E1h	00h	00h	00h	01h	LED Status



6.3.7. Set LED Control [E0 00 00 29 01 ...]

This command is used to set LED control

Command

Command	Class	INS	P1	P2	Lc	Data Out
Set LED Control	E0h	00h	00h	29h	01h	LED Status

Response Code

Response	Class	INS	P1	P2	Le	Data In
Result	E1h	00h	00h	00h	01h	LED Status

LED Status (1 byte)

LED Status	Description
Bit 2: Blue LED	1 = On; 0 = Off
Bit 3: Yellow LED	1 = On; 0 = Off
Bit 4-7: RFU	Other

6.3.8. Get UI Behaviour [E0 00 00 21 00]

This command is used to get the PCD UI Behaviour but save the setting without another command. This command should only be used for initial reader configuration.

Command

Command	Class	INS	P1	P2	Le
Get PICC UI Behaviour	E0h	00h	00h	21h	00h

Response Code

Response	Class	INS	P1	P2	Le	Data In
Result	E1h	00h	00h	00h	01h	PICC UI Behaviour



6.3.9. Set UI Behaviour [E0 00 00 21 01 ...]

This command is used to set the PICC UI behaviour.

Command

Command	Class	INS	P1	P2	Lc	Data Out
Set PICC UI Behaviour	E0h	00h	00h	21h	01h	PICC UI Behaviour

Response Code

Response	Class	INS	P1	P2	Le	Data In
Result	E1h	00h	00h	00h	01h	PICC UI Behaviour

UI Behaviour - 1 Byte, Bit Mask of following

Operating Parameter	Parameter	Description	Option
Bit 0	Accessing(LED Fast Blinking)	The UI behaviour of the reader	1 = Enable 0 = Disable
Bit 1	Waiting for Presence (LED On)		
Bit 2	Presence/Activated (LED On)		
Bit 3	Presence Event (Short Buzzer Beep)		
Bit 4	Card Removal Event (Short Buzzer Beep)		

Default Setting For PICC – 1Fh

Notes:

1. The Get/Set UI behaviour are excluding on SAM interface

6.3.10. Get BLE UI Behaviour [E0 00 00 4B 01 05]

This command is used to set the Read the current Behaviour for LEDs

Command

Command	Class	INS	P1	P2	Lc	Data Out
Get BLE UI Behaviours	E0h	00h	00h	4Bh	01h	05h

Response Code

Response	Class	INS	P1	P2	Le	Data In
Result	E1h	00h	00h	00h	01h	BLE and charging UI Behaviour



6.3.11. Set BLE UI Behaviour [E0 00 00 4B 02 05 ...]

This command is used to set the Set the Behaviours for Blue BLE LED

Command

Command	Class	INS	P1	P2	Lc	Data Out (1 st byte)	Data Out
Set BLE UI Behaviour	E0h	00h	00h	4Bh	02h	05h	BLE UI Behaviour

Response Code

Response	Class	INS	P1	P2	Le	Data In
Result	E1h	00h	00h	00h	01h	BLE UI Behaviour

BLE UI Behaviour - 1 Byte, Bit Mask of following

Operating Parameter	Parameter	Description	Option
Bit 0	Blue BLE LED	The LEDs will be control by reader.	1 = Enable 0 = Disable

Default Setting For BLE – 01h

6.3.12. Get Standby mode (Sleep Mode) Option [E0 00 00 50 00]

This command checks the Standby mode (sleep mode) timer.

Note: This is applicable only to firmware version 1.02.04 and later

Command

Command	Class	INS	P1	P2	Lc
Get Standby Mode (Sleep timer) Option	E0h	00h	00h	50h	00h

Response Code

Response	CLA	INS	P1	P2	Le	Data In
Result	E1h	00h	00h	00h	01h	Time

Standby

6.3.13. Set Standby Mode (Sleep Mode) Option [E0 00 00 48 ...]

By default. The reader will enter standby Mode (sleep mode) if there is no operation for 60 seconds. This command sets the time interval before entering standby Mode (sleep mode).

Note: This is applicable only to firmware version 1.02.04 and later

Command



Command	Class	INS	P1	P2	Data Out
Set Standby Mode (Sleep timer) Option	E0h	00h	00h	48h	Time

Response Code

Response	CLA	INS	P1	P2	Le	Data In
Result	E1h	00h	00h	00h	01h	Time

Where:

- Time** 1 byte: Timer
 00h = 60s (default)
 01h = 90s
 02h = 120s
 03h = 180s
 04h = No Standby Mode (Sleep mode)
 05h = 10s
 06h = 30s

6.3.14. Get Auto Power-Off Option [E0 00 00 0F 00]

This command checks the auto power-off timer.

Note: This is applicable only to PCB version 1.07 and firmware version 1.03.00 or later.

Command

Command	Class	INS	P1	P2	Lc
Get Auto Power-Off Option	E0h	00h	00h	0Fh	00h

Response Code

Response	CLA	INS	P1	P2	Le	Data In
Result	E1h	00h	00h	00h	01h	Time

6.3.15. Set Auto Power-Off Option [E0 00 00 0F 01 ...]

This command sets the time interval before auto power-off.

Note: This is applicable only to PCB version 1.06 and firmware version 1.03.00 or later.

Command

Command	Class	INS	P1	P2	Lc	Data Out
Set Auto Power Off Option	E0h	00h	00h	0Fh	01h	Time

Response Code



Response	CLA	INS	P1	P2	Le	Data In
Result	E1h	00h	00h	00h	01h	Time

Where:

- Time** 1 byte: Timer
 00h = Disable (default)
 01h = 5 mins
 02h = 10 mins
 03h = 15 mins
 FFh = immediately

6.3.16. Get Tx Power Value [E0 00 00 51 00]

This command read the Tx power of the Bluetooth.

Command

Command	Class	INS	P1	P2	Lc
Get Tx power Value	E0h	00h	00h	51h	00h

Response Code

Response	Class	INS	P1	P2	Le	Data In
Result	E1h	00h	00h	00h	01h	Tx Power

6.3.17. Set Tx Power Value [E0 00 00 49 ...]

This command change the Tx power of the Bluetooth.

Command

Command	Class	INS	P1	P2	Data Out
Get Tx power Value	E0h	00h	00h	49h	Tx Power

Response Code

Response	Class	INS	P1	P2	Le	Data In
Result	E1h	00h	00h	00h	01h	Tx Power

Where:

- Tx Power** 1 byte
 00h = -12 dBm, Distance : ~3 meters
 01h = -6 dBm(default), Distance : ~7 meters
 02h = 0 dBm, Distance: ~12 meters
 03h = 4 dBm, Distance: ~20 meters

Default Value – 01h



6.3.18. Get MAC Address [E0 00 00 43 00]

This command read the MAC address of the BLE reader

Command

Command	Class	INS	P1	P2	Lc
Get MAC Address	E0h	00h	00h	43h	00h

Response Code

Response	Class	INS	P1	P2	Le	Data In
Result	E1h	00h	00h	00h	06h	MAC address

Where:

MAC address 6 bytes

AA:BB:CC:DD:EE:FF is in Little-Endian

BLE MAC address: FF:EE:DD:CC:BB:AA

6.3.19. Get BLE Advertising Name [E0 00 00 44 00]

This command read the BLE advertising name.

Command

Command	Class	INS	P1	P2	Lc
Get BLE Advertising Name	E0h	00h	00h	44h	00h

Response Code

Response	Class	INS	P1	P2	Le	Data In
Result	E1h	00h	00h	00h	length	BLE advertising name



6.3.20. Get Battery Level [E0 00 00 52 00]

This command checks the current battery level.

Note: This is applicable when the reader is in Bluetooth mode.

Command

Command	Class	INS	P1	P2	Lc
Get Battery Level	E0h	00h	00h	52h	00h

Response Code

Response	Class	INS	P1	P2	Le	Data In
Result	E1h	00h	00h	00h	01h	Battery Level

Where:

- Battery Level 1 byte
- 64h = 100% battery
- 5Ah = 90% battery
- 50h = 80% battery
- 46h = 70% battery
- 3Ch = 60% battery
- 32h = 50% battery
- 28h = 40% battery
- 1Eh = 30% battery
- 14h = 20% battery
- 0Fh = 15% battery

6.3.21. Remove BLE Bonding Record [E0 00 00 5B 00]

This command removes BLE Bonding Record .

Note: This is applicable when the reader is in USB mode

Command

Command	Class	INS	P1	P2	Lc
Remove BLE Bonding Record	E0h	00h	00h	5Bh	00h

Response Code

Response	Class	INS	P1	P2	Le	Data In
Result	E1h	00h	00h	00h	02h	90h 00h



6.3.22. Read BLE Communication Mode [E0 00 00 77 00]

This command read the BLE communication mode.

Command

Command	Class	INS	P1	P2	Lc
Read BLE Communication Mode	E0h	00h	00h	77h	00h

Response Code

Response	Class	INS	P1	P2	Le	Data In
Result	E1h	00h	00h	00h	01h	Communication Mode

Default Value – 00h

6.3.23. Set BLE Communication Mode

This command set the BLE communication mode.

Step 1, get random number:

Command

Command	Class	INS	P1	P2	Lc
Get Random Number	E0h	00h	00h	75h	00h

Response Code

Response	Class	INS	P1	P2	Le	Data In
Result	E1h	00h	00h	00h	10h	16 bytes random numbers

Step 2, Set BLE communication mode:

Command

Command	Class	INS	P1	P2	Lc	Data Out
Set BLE Communication Mode	E0h	00h	00h	77h	20h	16 bytes encrypted random numbers + 16 bytes encrypted Mode Value

Where:

Mode Value	
Communication Mode	15 bytes don't care value

Response Code

Response	CLA	INS	P1	P2	Le	Data In
Result	E1h	00h	00h	00h	01h	Communication Mode

Communication Mode	Meaning
00h	Plain Text
01h	Authenticated



6.3.24. Customer Master Key Rewrite

This command set the customer master key.

Step 1, get random number:

Command

Command	Class	INS	P1	P2	Lc
Get Random Number	E0h	00h	00h	75h	00h

Response Code

Response	Class	INS	P1	P2	Le	Data In
Result	E1h	00h	00h	00h	10h	16 bytes random numbers

Step 2, customer master key rewrite:

Command

Command	Class	INS	P1	P2	Lc	Data Out
Customer Master Key Rewrite	E0h	00h	00h	76h	20h	16 bytes encrypted random numbers + 16 bytes encrypted New Master Key

Response Code

Response	CLA	INS	P1	P2	Le	Data In
Result	E1h	00h	00h	00h	02h	SW1 SW2

SW1 SW2	Meaning
90 00h	Success
67 00h	Fail



Appendix A. NDEF Message

This section shows how to use NDEF message to encode the URL onto the Ntag.

For the data format, please refer to NFC Forum NFC Data Exchange Format (NDEF) Specifications 1.0.

Example:

NDEF Message = { D1 01 0B 55 02 61 63 73 2E 63 6F 6D 2E 68 6Bh}

Offset	Content	Length	Description
0	D1	1	NDEF header. TNF = 01h, SR=1, MB=1, ME=1
1	01	1	Record name length (1 byte)
2	0B	1	The length of the URI payload (11 bytes)
3	55 ("U")	1	Record type: "U"
4	02	1	Abbreviation: "https://www."
5	61 63 73 2E 63 6F 6D 2E 68 6B	10	The URL itself. "acs.com.hk"

Encode to Ntag = {03 0F D1 01 0B 55 01 61 63 73 2E 63 6F 6D 2E 68 6B FEh}

Offset	Content	Length	Description
0	03	1	TLV header. 03h = NDEF message
1	0F	1	The length of the NDEF message (15 byte)
2	D1 01 0B 55 01 61 63 73 2E 63 6F 6D 2E 68 6B	15	NDEF Message
17	FE	1	TLV header. FEh = End of record



Appendix B. Slot Status and Slot Error

Each Bulk-IN Message contains the values of Slot Error and Slot Status registers.

Offset	Field	Size	Value	Description
0	bmICCStatus	2 bits	0, 1, 2	0 - An ICC is present and active (power is on and stable, RST is inactive) 1 - An ICC is present and inactive (not activated or shut down by hardware error) 2 - No ICC is present 3 - RFU
2	bmRFU	4 bits	RFU	
6	bmCommandStatus	2 bits	0, 1, 2	0 - Processed without error 1 - Failed (error code provided by the error register) 2 - Time Extension is requested 3 - RFU

Table 17: Slot Status register

Error Code	Error Name	Possible Causes
FFh	CMD_ABORTED	Host aborted the current activity
FEh	ICC_MUTE	CCID timed out while talking to the ICC
FDh	XFR_PARITY_ERROR	Parity error while talking to the ICC
FCh	XFR_OVERRUN	Overflow error while talking to the ICC
FBh	HW_ERROR	An all inclusive hardware error occurred
F8h	BAD_ATR_TS	
F7h	BAD_ATR_TCK	
F6h	ICC_PROTOCOL_NOT_SUPPORTED	
F5h	ICC_CLASS_NOT_SUPPORTED	
F4h	PROCEDURE_BYTE_CONFLICT	
F3h	DEACTIVATED_PROTOCOL	
F2h	BUSY_WITH_AUTO_SEQUENCE	Automatic Sequence Ongoing
E0h	CMD_SLOT_BUSY	A second command was sent to a slot which was already processing a command.
C0h to 81h	User Defined	
80h and those filling	RFU	



Error Code	Error Name	Possible Causes
the gaps		
7Fh to 01h	Index of not supported / incorrect message parameter	01h: Bad dwLength 05h: bSlot does not exist 07h: bPowerselect error (not supported) 08h: Bad wLevelParameter 0Ah: FI – DI pair invalid or not supported 0Bh: Invalid TCCKTS parameter 0Ch: Guard time not supported 0Dh: T = 0 WI invalid or not supported T = 1 BWI or CWI invalid or not supported 0Eh: Clock stop support requested invalid or not supported 0Fh: IFSC size invalid or not supported 10h: NAD value invalid or not supported
00h	Command not supported	

Table 18: Slot error register when bmCommandStatus = 1