



**Advanced Card Systems Ltd.**  
Card & Reader Technologies

# ACR38T-D1 Smart Card Reader



Technical Specifications V1.07



## Table of Contents

<b>1.0.</b>	<b>Introduction .....</b>	<b>3</b>
1.1.	Smart Card Reader.....	3
1.2.	Ease of Integration.....	3
<b>2.0.</b>	<b>Features .....</b>	<b>4</b>
<b>3.0.</b>	<b>Supported Card Types .....</b>	<b>5</b>
3.1.	MCU Cards .....	5
3.2.	Memory-based Smart Cards.....	5
<b>4.0.</b>	<b>Typical Applications.....</b>	<b>6</b>
<b>5.0.</b>	<b>Technical Specifications.....</b>	<b>7</b>
<b>6.0.</b>	<b>Inserting and removing the SIM card.....</b>	<b>9</b>



## 1.0. Introduction

Sporting a new sleek case, the ACR38T-D1 SIM-sized smart card reader is a small USB device that delivers more than it meets the eye. A powerful reader that packs a lot in feature despite its size, it has all the functionalities of a standard-sized ACR38 PC-linked Smart Card Reader.



### 1.1. Smart Card Reader

ACR38T-D1 supports ISO 7816 Class A, B, and C smart cards and works with most memory cards and microprocessor cards with the T=0 and T=1 protocol.

This device houses the powerful ACR38 core, which has been proven to support highly demanding smart card applications. It also features a USB Full Speed interface and a smart card read/write speed of up to 344 Kbps. Highly durable, ACR38T-D1 can last for at least 100,000 card insertion cycles.

### 1.2. Ease of Integration

ACR38T-D1 has PC/SC and CCID compliance that make for its seamless interoperability and use across different platforms, particularly in computer-based environments. In addition, ACR38T-D1 may now be used on mobile devices running the Android™ platform with versions 3.1 and later.

With its numerous features, ACR38T-D1 can be used in different applications such as Internet Banking, e-Payment, and Network Security.



## 2.0. Features

- USB Full Speed Interface
- Plug and Play – CCID support brings utmost mobility
- Smart Card Reader:
  - Support ISO 7816 Class A, B, and C (5 V, 3 V, 1.8 V) SIM-sized cards
  - Supports microprocessor cards with T=0 and T=1 protocol
  - Supports memory cards
  - Supports PPS (Protocol and Parameters Selection)
  - Features Short Circuit Protection
- Application Programming Interface:
  - Supports PC/SC
  - Supports CT-API (through wrapper on top of PC/SC)
- Supports Android™ 3.1 and later<sup>1</sup>
- Compliant with the following standards:
  - EN 60950/IEC 60950
  - ISO 7816
  - USB Full Speed
  - PC/SC
  - CCID
  - CE
  - FCC
  - WEEE
  - RoHS 2
  - REACH
  - VCCI (Japan)
  - Microsoft® WHQL

---

<sup>1</sup> Uses an ACS-defined Android Library



## 3.0. Supported Card Types

### 3.1. MCU Cards

The ACR38T-D1 operates with MCU cards following either the T=0 or T=1 protocol.

### 3.2. Memory-based Smart Cards

The ACR38T-D1 works with several memory-based smart cards such as:

- Cards following the I2C bus protocol (free memory cards) with maximum 128 bytes page with capability, including:
  - Atmel®: AT24C01/02/04/08/16/32/64/128/256/512/1024
  - SGS-Thomson: ST14C02C, ST14C04C
  - Gemplus: GFM1K, GFM2K, GFM4K, GFM8K
- Cards with secure memory IC with password and authentication, including:
  - Atmel®: AT88SC153 and AT88SC1608
- Cards with intelligent 1 KB EEPROM with write-protect function, including:
  - Infineon®: SLE4418, SLE4428, SLE5518 and SLE5528
- Cards with intelligent 256-byte EEPROM with write-protect function, including:
  - Infineon®: SLE4432, SLE4442, SLE5532 and SLE5542
- Cards with '104' type EEPROM non-reloadable token counter cards, including:
  - Infineon®: SLE4406, SLE4436, SLE5536 and SLE6636
- Cards with intelligent 416-bit EEPROM with internal PIN check, including:
  - Infineon®: SLE4404
- Cards with Security Logic with Application Zone(s), including:
  - Atmel®: AT88SC101, AT88SC102 and AT88SC1003



## 4.0. Typical Applications

- e-Government
- e-Banking and e-Payment
- e-Healthcare
- Public Key Infrastructure
- Network Security
- Access Control
- Loyalty Program

## 5.0. Technical Specifications

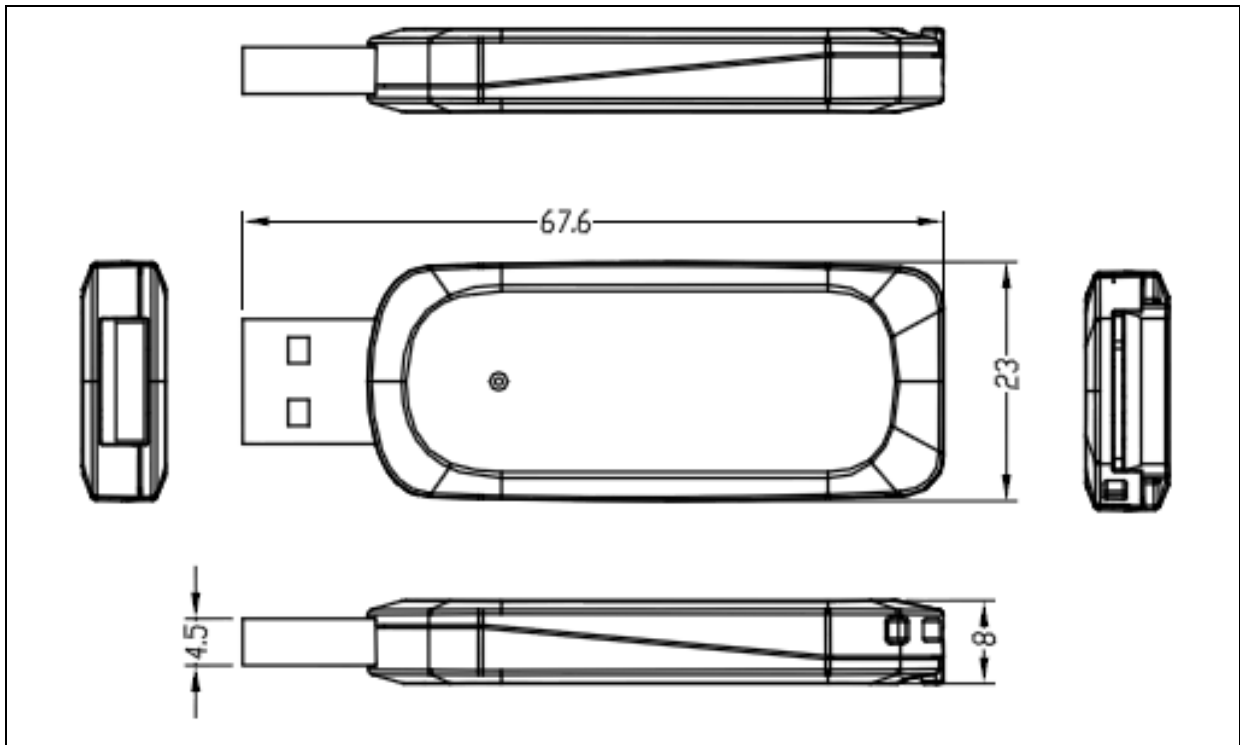

### Physical Characteristics

Dimensions ..... 67.6 mm (L) x 23.0 mm (W) x 8.0 mm (H)  
 Weight ..... 12 g  
 Color ..... White

### USB Host Interface

Protocol ..... USB CCID  
 Connector Type ..... Standard Type A  
 Power Source ..... From USB port  
 Speed ..... USB Full Speed (12 Mbps)  
 Supply Voltage ..... 5 V

### Contact Smart Card Interface

Number of Slot ..... 1 SIM-sized Card Slot  
 Standard ..... ISO 7816 Parts 1-3, Class A, B, C (5 V, 3 V, 1.8 V)  
 Protocol ..... T=0; T=1; Memory Card Support  
 Supply Current ..... Max. 50 mA  
 Smart Card Read/Write Speed ..... 9.6 Kbps – 344 Kbps  
 Short Circuit Protection ..... (+5) V/GND on all pins  
 Clock Frequency ..... 4 MHz  
 Card Connector Type ..... Contact  
 Card Insertion Cycles ..... Min. 10,000

### Built-in Peripheral

LED ..... Green

### Application Programming Interface

PC-linked Mode ..... PC/SC  
 ..... CT-API (through wrapper on top of PC/SC)

### Operating Conditions

Temperature ..... 0 °C – 60 °C  
 Humidity ..... Max. 90% (non-condensing)  
 MTBF ..... 500,000 hrs



**Certifications/Compliance**

EN 60950/IEC 60950, ISO 7816, USB Full Speed, PC/SC, CCID, CE, FCC, WEEE, RoHS 2, REACH  
VCCI (Japan), Microsoft® WHQL

**Device Driver Operating System Support**

Windows® Embedded Compact 7, Windows® XP, Windows Vista®, Windows® 7, Windows® 8, Windows® 8.1, Windows® 10  
Windows® Server 2003, Windows® Server 2008, Windows® Server 2008 R2, Windows® Server 2012, Windows® Server 2012 R2  
Linux®, Mac OS®, Solaris, Android™ 3.1 and later





## 6.0. Inserting and removing the SIM card

To insert the SIM card:

1. Insert the SIM card into the card slot with its contact pins facing down.

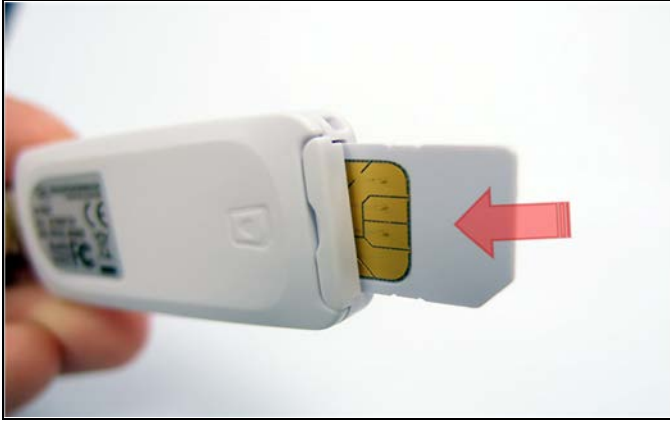

To remove the SIM card:

1. Pull out the slide tab completely, and then push it back again.





2. Notice that the SIM card will remain drawn out. Pull out the SIM card from the slot to remove it completely.

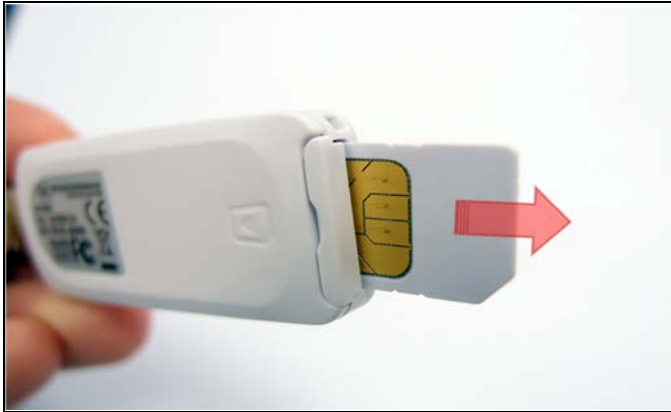

Android is a trademark of Google Inc.  
Atmel is registered trademark of Atmel Corporation or its subsidiaries, in the US and/or other countries.  
Infineon is a registered trademark of Infineon Technologies AG.  
Linux® is the registered trademark of Linus Torvalds in the U.S. and other countries.  
Mac OS is a trademark of Apple Inc., registered in the U.S. and other countries.  
Microsoft, Windows, and Windows Vista are registered trademarks of Microsoft Corporation in the United States and/or other countries.