



Advanced Card Systems Ltd.
Card & Reader Technologies

ACR83 PINeasy



Technical Specifications V2.08



Table of Contents

1.0. Introduction	3
2.0. Features	4
3.0. Typical Applications.....	5
4.0. Technical Specifications.....	6

List of Figures

Figure 1 : ACR83U-A1 Features	4
-------------------------------------	---



1.0. Introduction

ACR83 PINeasy is a USB reader featuring a keypad and display, supporting Secure PIN Entry (SPE). The PIN (Personal Identification Number) is securely entered on its keypad and then authenticated within the device. Since the PIN is entered into the secure ACR83 PINeasy rather than the vulnerable personal computer or workstation, the possibility of a Virus/Trojan or USB sniffer getting hold of the PIN is eliminated.

ACR83 PINeasy, which fits perfectly on the palm of your hand, is one of the smallest PIN-pad readers in the market. To authenticate yourself, all you have to do is to connect the reader to the USB port of a computer, insert the smart card, follow the command on the LCD and enter your PIN.

Additionally, the ACR83 PINeasy is compliant with major computing, banking and safety standards such as Microsoft® WHQL (Windows Hardware Quality Labs), PC/SC, EMV™ Level 1, CE and FCC, equipping ACR83 to be a device that you can trust.

2.0. Features

- USB Full Speed Interface
- Contact Interface:
 - Supports ISO 7816 Class A, B and C (5 V, 3 V and 1.8 V) cards
 - Supports microprocessor cards with T=0 and/or T=1 protocol
- Supports Protocol and Parameters Selection (PPS)
- Supports Secure PIN Entry (SPE)
- Built-in Peripherals:
 - Fourteen-key Keypad
 - 2 rows x 16 characters dot matrix LCD, with 5 dots x 8 dots each character
- Supports Android™ 3.1 and later¹
- Compliant with the following standards:
 - IEC/EN 60950
 - ISO 7816
 - EMV™ Level 1 (Contact)
 - PC/SC 2.0 Part 10 – Secure PIN Entry
 - CCID
 - CE
 - FCC
 - RoHS 2
 - Microsoft® WHQL

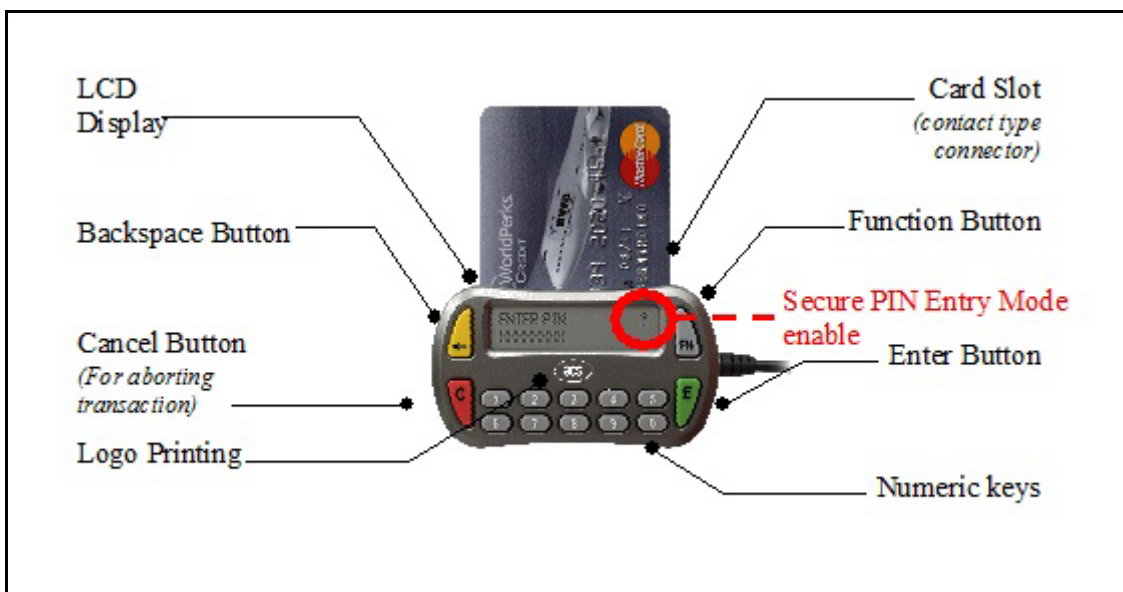

Figure 1: ACR83U-A1 Features

¹Uses an ACS-defined Android Library



3.0. Typical Applications

- e-Government
- e-Banking and e-Payment
- e-Healthcare
- Transportation
- Loyalty Program



4.0. Technical Specifications

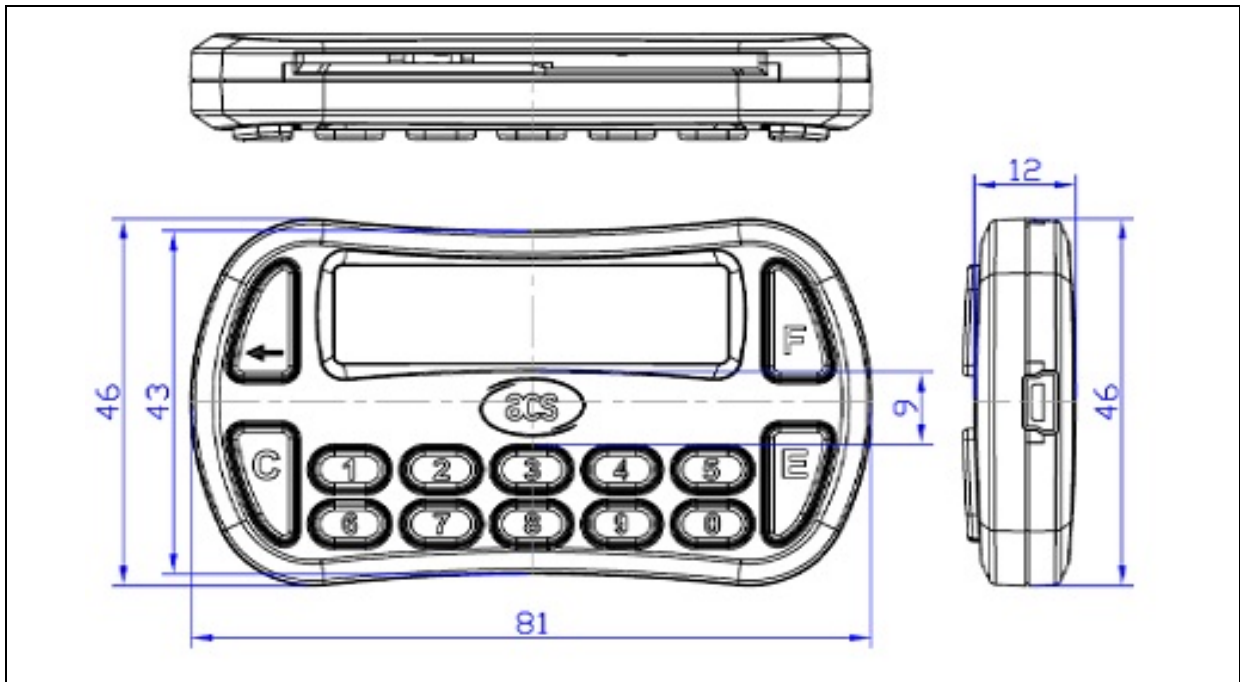

Physical Characteristics

Dimensions	81 mm (L) x 46 mm (W) x 12 mm (H)
Weight.....	65 g
Color	Metallic Grey
Cable length.....	1.5 m fixed cable

USB Host Interface

Protocol.....	USB CCID
Type.....	Four Lines: +5 V, GND, D+ and D-
Connector Type.....	Standard Type A
Power Source.....	From USB port
Speed.....	USB Full Speed (12 Mbps)
Supply Voltage.....	5 V
Supply Current.....	Max. 50 mA

Contact Smart Card Interface

Number of Slots	1 Full-sized Card Slot
Standard	ISO 7816 Parts 1-3, Class A, B, C (5 V, 3 V, 1.8 V)
Protocol.....	T=0; T=1; Memory Card Support
Supply Current	Max. 60 mA
Smart Card Read/ Write Speed	1.743 Kbps – 250 Kbps
Short Circuit Protection	(+5) V/GND on all pins
Clock Frequency	4 MHz
Card Connector Type.....	ICC Slot 1: Contact
Card Insertion Cycles.....	Min. 100,000

Built-in Peripherals

LCD.....	2 rows x 16 characters, each character 5 x 8 dots
Keypad.....	14 keys (10 numeric key and 4 function keys)

Operating Conditions

Temperature.....	0 °C - 50 °C
Humidity.....	Max. 90% (non-condensing)
MTBF	500,000 hrs

Certifications/Compliance

IEC/EN 60950, ISO 7816, USB Full Speed, EMV™ Level 1 (Contact), PC/SC 2.0 Part 10 – Secure PIN Entry, CCID, CE, FCC, RoHS 2, Microsoft® WHQL



Device Driver Operating System Support

Windows® 2000, Windows® XP, Windows Vista®, Windows® 7, Windows® 8, Windows® 8.1, Windows® 10
Windows® Server 2003, Windows® Server 2008, Windows® Server 2008 R2, Windows® Server 2012,
Windows® Server 2012 R2
Linux®, Mac OS®, Android™ 3.1 and later



Android is a trademark of Google Inc.
EMV is a registered trademark or trademark of EMVCo LLC in the United States and other countries.
Linux® is the registered trademark of Linus Torvalds in the U.S. and other countries.
Microsoft, Windows and Windows Vista are registered trademarks of Microsoft Corporation in the United States and/or other countries.
Mac OS is a trademark of Apple Inc., registered in the U.S. and other countries.